

L.A. SLEEVE

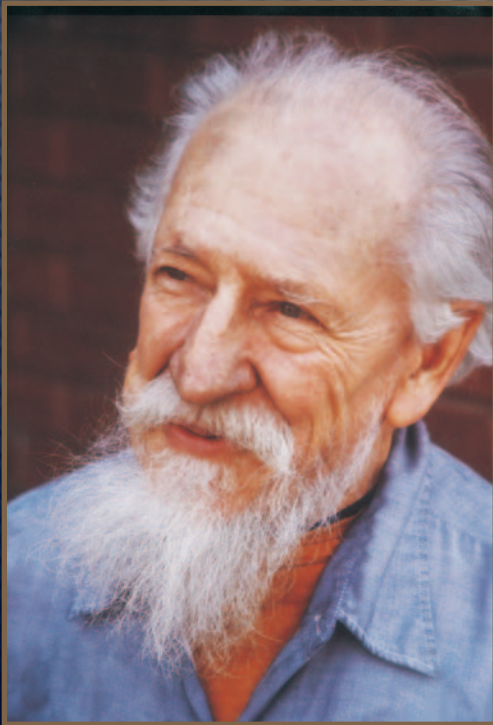

Fifty Years of Quality, Service, Technology. . .



L.A.SLEEVE CO. founded in 1945 by family patriarch, Nicholas W. Metchkoff, **L.A.SLEEVE CO.** has been producing centrifugally spun-cast chrome-moly iron alloy cylinder sleeves for all engine repair markets. Currently **L.A.SLEEVE CO.** manufactures cylinder sleeves for the watercraft, motorcycle, snowmobile, atv, marine, and automotive markets. A family owned business for three generations, **L.A.SLEEVE CO.** provides its customer with expertise in engineering, sleeve design and installation. **L.A.SLEEVE CO.** distributes a complete line of engine hard parts. Rebuilders can use our "One-Stop Shop" to purchase parts from Pro-X and Wiseco pistons to lubricants, connecting rods, bearings, and even thrust washers. **L.A.SLEEVE CO.** is the North American supplier of Pro-X pistons, connecting rods and various OEM replacements parts. We are the source for a vast array of OEM components. The West Coast's leading distributor for Wiseco forged pistons for nearly two decades, **L.A.SLEEVE CO.** features a fully stocked warehouse of all of Wiseco's products. With over 1,000 two-stroke and four stroke cylinder sleeve part numbers covering models thirty years old or more, **L.A.SLEEVE CO.** provides today's racers and vintage rebuilders alike, cylinder sleeves to save worn cylinders. Most cylinder sleeve models are still produced and stocked on the shelf in our 35,000 square foot warehouse and manufacturing facility. All sleeves are manufactured in Santa Fe Springs, California.

AUTOMOTIVE CATALOG TABLE OF CONTENTS

How to Order Custom Sleeves	2	Cut to Length Sleeves – Foreign Cars	47
Progressive Size List	4	Acura	47
Sleeve Interchange Charts	10	Alfa Romeo	47
All Purpose Sleeves	21	Audi	47
All Purpose Flange Sleeves	23	Aston Martin	47
Cut to Length Sleeves – Truck - Tractor - Forklift. ..	24	Austin	47
Allis Chalmers	24	Austin Healy	47
Case Repair Ring	24	BMW	48
Caterpillar	24	Chevrolet Luv - Sprint	48
Caterpillar Thread Repair Bushing	24	Chrysler, Dodge	48
Caterpillar Repair Ring	24	Daewoo	48
Continental	25	Datsun, Nissan	49
Continental Flange Type Sleeves	25	Ferrari	49
Cummins Repair Ring, Cam Bushing, Thread Inserts	26	Fiat	50
Detroit Diesel	27	Ford Courier	50
Detroit Diesel Thread Repair Bushings	27	Geo	50
Ford Tractor	27	Hilman	50
Dodge Trucks	28	Honda	50
Ford Trucks	28	Hyundai	51
G.M.C. Trucks	30	Infiniti	51
Hino	32	Isuzu	51
Hercules	32	Jaguar	51
International	32	Jensen-Healy (Lotus)	51
International Flange Type Sleeves	33	Lexus	51
Isuzu Truck	33	Lamborghini	51
John Deere	33	Maserati	52
Kubota	33	Mazda	52
Mack	34	Mercedes	52
Mazda	34	MG	53
Navistar Trucks	34	Mitsubishi	53
Nissan Forklift	34	Opel	54
Perkins	34	Porsche	54
Scania	34	Peugeot	54
Thermo-King	34	Saab	54
Volvo	34	Renault	54
Yanmar	34	Simca	54
Cut to Length Sleeves – American Cars	35	Subaru	54
American Motors	35	Sunbeam	55
Buick	35	Suzuki	55
Cadillac	36	Toyota	55
Chevrolet	36	Triumph	56
Chrysler	38	Volkswagen	56
Dodge	39	Volvo	56
Eagle	40	Cut to Length Sleeves – Industrial Engines	57
Ford	41	Briggs & Stratton	57
Jeep	42	Chrysler Industrial	57
Lincoln	43	Ford Industrial	57
Mercury	43	Kohler	57
Oldsmobile	44	Leroi	57
Packard	45	Onan	58
Plymouth	45	Waukesha	58
Pontiac	46	Wisconsin	58
Saturn	46	Wisconsin Robin	58
Studebaker	46	Compressor Sleeves	59
		Ductile - Nodule Iron Sleeves	61
		Top Fuel	62
		Fraction / Decimal Equivalent Chart	63
		Millimeter / Decimal Equivalent Chart	64

HOW TO ORDER A CUSTOM SLEEVE

Photocopy and FAX this custom sleeve form. Designate appropriate dimensions on the drawing and provide the information requested. L.A.SLEEVE will quote pricing and lead time by return FAX. Note that custom sleeve orders require a one-half deposit to initiate production.

CUSTOMER # _____ CONTACT _____ DATE _____
NAME _____
ADDRESS _____
CITY _____ STATE _____ ZIP _____
PHONE _____ FAX _____

METHOD OF PAYMENT:

- MONEY ORDER
 MASTERCARD/VISA/DISCOVER

CARD NO. _____ EXP. _____
NAME ON CARD _____
BILLING ADDRESS _____
CITY _____ STATE _____ ZIP _____

RETURN UPS SHIPPING SERVICE:

- NEXT DAY AIR 2ND DAY AIR
 3-DAY GROUND SELECT GROUND SERVICE

SHIP TO:
L.A.SLEEVE CYLINDER DEPT.
12051 RIVERA RD.
SANTA FE SPRINGS, CA 90670

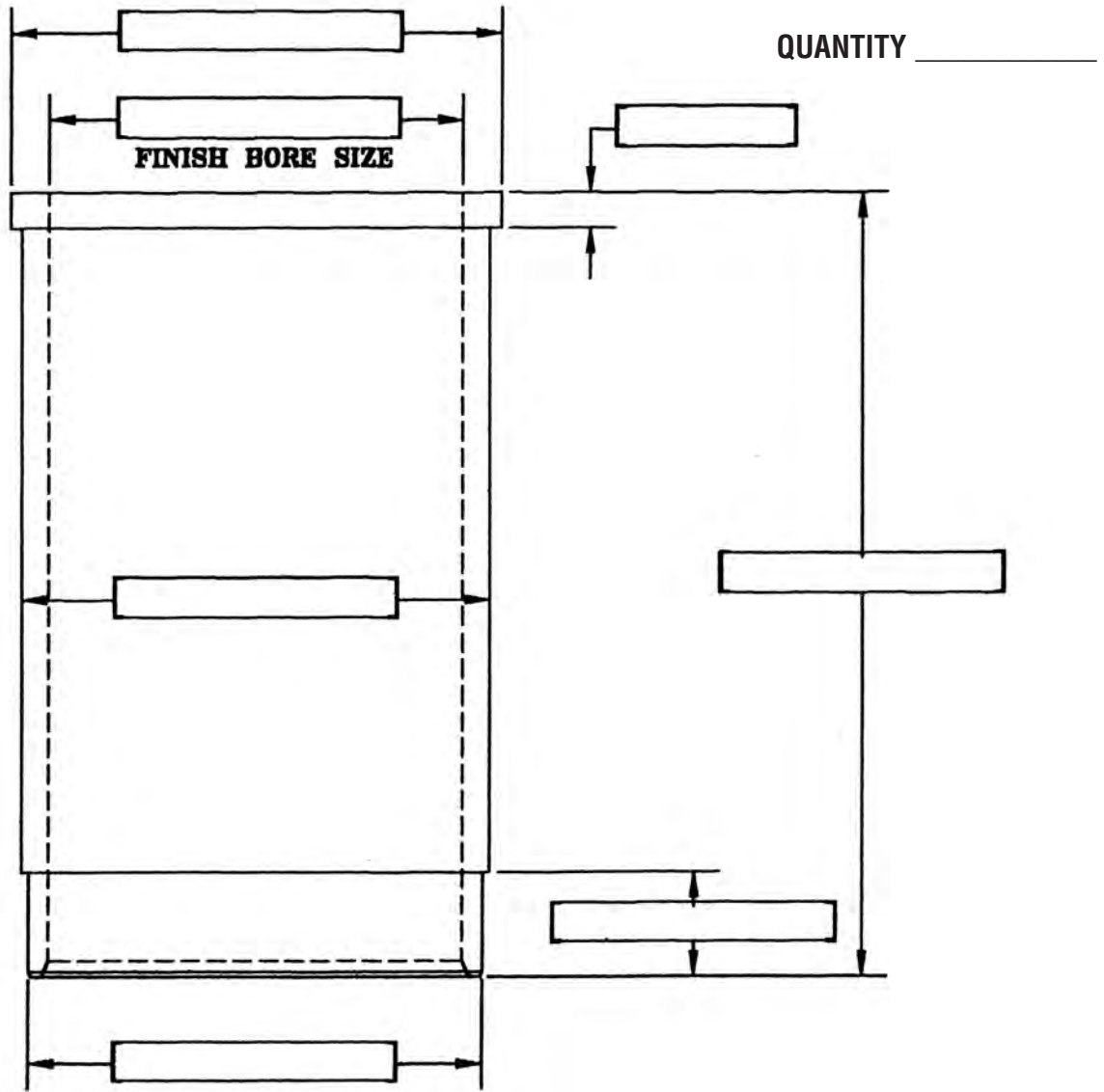

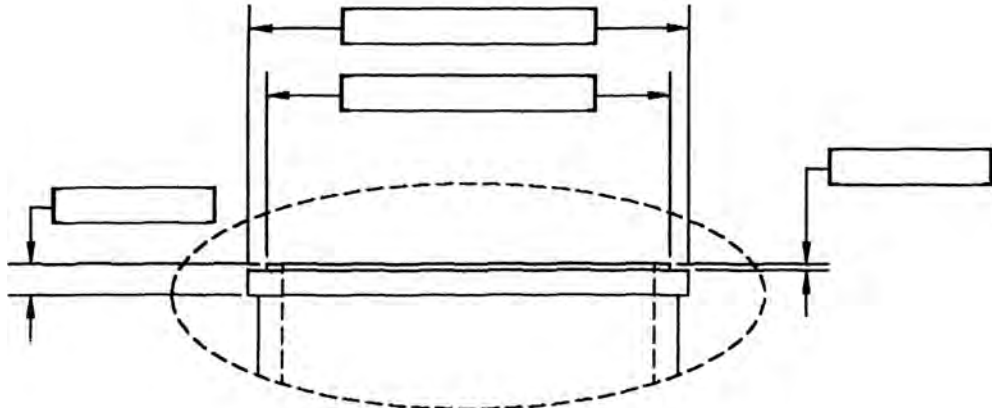

SPIGOT / FIRE RING

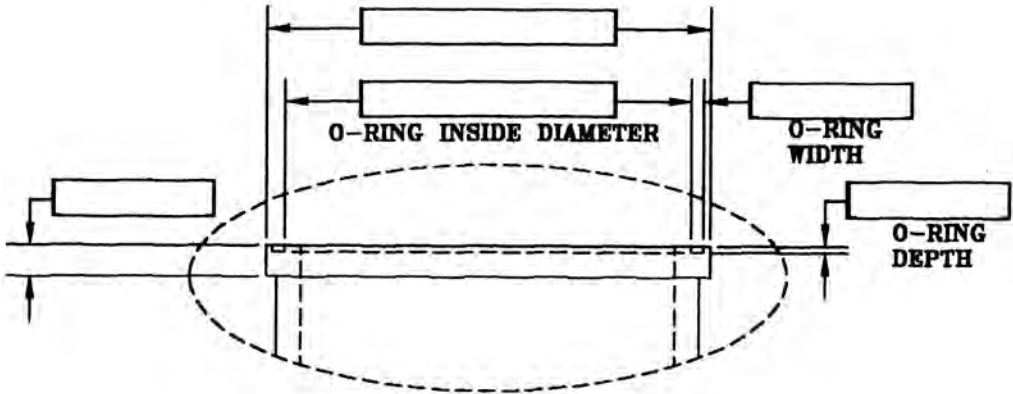

O-RING TYPE SLEEVE (IF APPLICABLE)

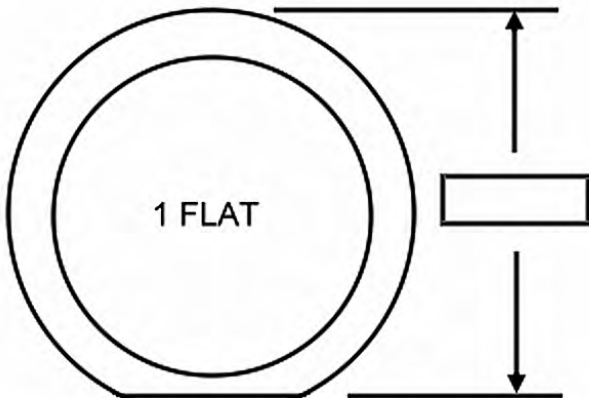
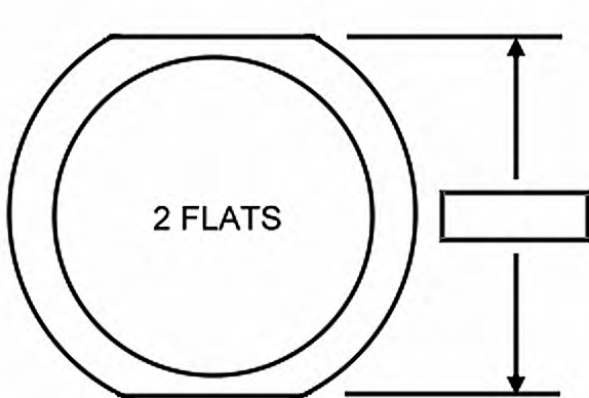

FLAT DIMENSIONS

UNIVERSAL AUTOMOTIVE PROGRESSIVE SIZE LIST

L.A. SLEEVE

CYLINDER BORE		1/16" Wall		3/32" Wall		1/8" Wall		5/32" Wall		SLEEVE LENGTH
MM	IN	Part No.	O.D.	Part No.	O.D.	Part No.	O.D.	Part No.	O.D.	
34.93mm	1.375"			LA-106	1.562"	L-106	1.625"			4.500"
36.5mm	1.437"			LA-107	1.625"	L-107	1.687"			4.500"
38.1mm	1.500"			LA-108	1.687"	L-108	1.750"			4.500"
39.67mm	1.562"			LA-109	1.750"	L-109	1.812"			4.500"
41.27mm	1.625"			LA-110	1.812"	L-110	1.875"			6.500"
42.85mm	1.687"			LA-111	1.875"	L-111	1.937"			6.500"
44.45mm	1.750"			LA-112	1.937"	L-112	2.000"			6.500"
46.02mm	1.812"			LA-113	2.000"	L-113	2.062"			6.500"
47.62mm	1.875"			LA-114	2.062"	L-114	2.125"			6.500"
49.2mm	1.937"			LA-115	2.125"	L-115	2.187"			6.500"
50.8mm	2.000"			LA-200	2.187"	L-200	2.250"			6.250"
52.37mm	2.062"			LA-201	2.250"	L-201	2.312"			6.250"
53.97mm	2.125"			LA-202	2.312"	L-202	2.375"			6.250"
55.55mm	2.187"			LA-203	2.375"	L-203	2.437"			6.250"
57.15mm	2.250"			LA-204	2.437"	L-204	2.500"			6.250"
58.72mm	2.312"			LA-205	2.500"	L-205	2.562"			6.250"
60mm	2.362"	T-228	2.478"	LA-228	2.549"	L-228	2.612"			4.527"
60.33mm	2.375"	C-32	2.500"	CA-32	2.562"	CL-32	2.625"			4.500"
60.33mm	2.375"	T-206A	2.500"	LA-206A	2.562"	L-206A	2.625"			6.000"
60.33mm	2.375"			LA-206	2.562"	L-206	2.625"			6.250"
61.9mm	2.437"	T-207F	2.562"	LA-207F	2.625"	L-207F	2.687"			4.330"
61.9mm	2.437"			LA-207	2.625"	L-207	2.687"			6.250"
62.92mm	2.477"	T-230	2.606"	LA-230	2.665"	L-230	2.727"			5.156"
63.5mm	2.500"	C-41B	2.625"	CA-41B	2.687"	CL-41B	2.750"			4.500"
63.5mm	2.500"	T-208A	2.625"	LA-208A	2.687"	L-208A	2.750"			6.000"
63.5mm	2.500"			LA-208	2.687"	L-208	2.750"			6.250"
64mm	2.519"	T-296	2.644"	LA-296	2.706"	L-296	2.769"			6.500"
64.6mm	2.542"	T-232	2.667"	LA-232	2.729"	L-232	2.792"			5.280"
65.1mm	2.562"	T-209F	2.687"	LA-209F	2.750"	L-209F	2.812"			4.409"
65.1mm	2.562"	C-42B	2.687"	CA-42B	2.750"	CL-42B	2.812"			4.375"
65.1mm	2.562"	C-43	2.687"	CA-43	2.750"	CL-43	2.812"			4.500"
65.1mm	2.562"	T-209	2.687"	LA-209	2.750"	L-209	2.812"			6.250"
66.5mm	2.618"	T-29	2.750"	LA-29	2.812"	L-29	2.875"			6.250"
66.68mm	2.625"	C-45B	2.750"	CA-45B	2.812"	CL-45B	2.875"			4.500"
66.68mm	2.625"			LA-210	2.812"	L-210	2.875"			6.250"
68mm	2.677"	T-238	2.812"	LA-238	2.875"	L-238	2.937"			5.250"
68mm	2.677"	T-238F	2.812"	LA-238F	2.875"	L-238F	2.937"			5.826"
68mm	2.677"	T-238M	2.812"	LA-238M	2.875"	L-238M	2.937"			6.500"
68.25mm	2.687"			LA-211	2.875"	L-211	2.937"			8.250"
69.289mm	2.727"	T-274	2.852"	LA-274	2.915"	L-274	2.978"			5.312"
69.5mm	2.736"	T-274V	2.852"	LA-274V	2.915"	L-274V	2.978"			6.500"
69.85mm	2.750"	T-177	2.875"	LA-177	2.937"	L-177	3.000"			5.875"
69.85mm	2.750"			LA-212	2.937"	L-212	3.000"			8.250"
70mm	2.755"	T-212M	2.875"	LA-212M	2.937"	L-212M	3.000"			6.500"
70mm	2.755"	T-212C	2.875"	LA-212C	2.937"	L-212C	3.000"			7.000"
70.6mm	2.780"	T-243	2.905"	LA-243	2.967"	L-243	3.030"			5.562"
70.6mm	2.780"	T-243G	2.905"	LA-243G	2.967"	L-243G	3.030"			6.500"
71mm	2.795"	T-291A	2.920"	LA-291A	2.982"	L-291A	3.045"			6.000"
71.42mm	2.812"			LA-213	3.000"	L-213	3.062"			8.250"
72mm	2.834"	T-56Z	2.959"	LA-56Z	3.022"	L-56Z	3.085"			4.730"
72mm	2.834"	T-56F	2.959"	LA-56F	3.022"	L-56F	3.085"			5.812"

CYLINDER BORE		1/16" Wall		3/32" Wall		1/8" Wall		5/32" Wall		SLEEVE LENGTH
MM	IN	Part No.	O.D.	Part No.	O.D.	Part No.	O.D.	Part No.	O.D.	
72mm	2.834"	T-56	2.959"	LA-56	3.022"	L-56	3.085"			6.250"
73mm	2.875"	T-81	3.000"	LA-81	3.062"	L-81	3.125"			4.625"
73mm	2.875"	T-214F	3.000"	LA-214F	3.062"	L-214F	3.125"			5.250"
73mm	2.875"	T-214A	3.000"	LA-214A	3.062"	L-214A	3.125"			6.000"
73mm	2.875"	T-214B	3.000"	LA-214B	3.062"	L-214B	3.125"			6.500"
73mm	2.875"			LA-214	3.062"	L-214	3.125"			8.250"
73.647mm	2.899"	T-275	3.025"	LA-275	3.087"	L-275	3.150"			5.312"
73.647mm	2.899"	T-275T	3.025"	LA-275T	3.087"	L-275T	3.150"			6.250"
74mm	2.913"	T-245	3.038"	LA-245	3.100"	L-245	3.163"			6.500"
74.6mm	2.937"	T-215T	3.062"	LA-215T	3.125"	L-215T	3.187"			5.750"
74.6mm	2.937"	T-215K	3.062"	LA-215K	3.125"	L-215K	3.187"			6.500"
74.6mm	2.937"			LA-215	3.125"	L-215	3.187"			8.250"
75mm	2.952"	T-247A	3.077"	LA-247A	3.140"	L-247A	3.202"			6.250"
75mm	2.952"	T-276	3.077"	LA-276	3.140"	L-276	3.202"			6.500"
75.4mm	2.968"	T-248	3.093"	LA-248	3.156"	L-248	3.218"			6.500"
76.2mm	3.000"	T-31C	3.125"	LA-31C	3.187"	L-31C	3.250"			6.000"
76.2mm	3.000"	T-31	3.125"	LA-31	3.187"	L-31	3.250"			6.375"
76.2mm	3.000"	T-30	3.125"	LA-30	3.187"	L-30	3.250"			7.500"
76.2mm	3.000"			LA-300	3.187"	L-300	3.250"			8.250"
76.5mm	3.011"	T-277	3.125"	LA-277	3.187"	L-277	3.250"			6.500"
77mm	3.031"	T-860	3.156"	LA-860	3.218"	L-860	3.281"			6.125"
77.77mm	3.062"			LA-301	3.250"	L-301	3.312"			8.250"
78mm	3.070"	T-602	3.187"	LA-602	3.250"	L-602	3.312"			6.500"
78.48mm	3.090"			LA-674	3.253"					6.505"
78.48mm	3.090"			LA-673	3.263"					6.505"
79mm	3.110"	T-253	3.235"	LA-253	3.298"	L-253	3.360"			6.000"
79.38mm	3.125"	T-706V	3.250"	LA-706V	3.312"	L-706V	3.375"			5.937"
79.38mm	3.125"	T-706A	3.250"	LA-706A	3.312"	L-706A	3.375"			6.875"
79.38mm	3.125"	T-706	3.250"	LA-706	3.312"	L-706	3.375"			8.125"
79.38mm	3.125"			LA-302	3.312"	L-302	3.375"			9.250"
79.6mm	3.136"	T-278	3.250"	LA-278	3.312"	L-278	3.375"			6.500"
80mm	3.150"	T-254F	3.275"	LA-254F	3.337"	L-254F	3.399"			5.625"
80mm	3.150"	T-298	3.275"	LA-298	3.337"	L-298	3.399"			5.937"
80mm	3.150"	T-89	3.275"	LA-89	3.337"	L-89	3.399"			6.000"
80mm	3.150"	T-254	3.275"	LA-254	3.337"	L-254	3.399"			6.500"
80.25mm	3.159"	T-280	3.275"	LA-280	3.337"	L-280	3.399"			6.062"
80.25mm	3.159"	T-255	3.275"	LA-255	3.337"	L-255	3.399"			6.250"
80.5mm	3.169"	T-361	3.295"	LA-361	3.357"	L-361	3.420"			6.500"
81mm	3.187"	T-603C	3.312"	LA-603C	3.375"	L-603C	3.437"			5.937"
81mm	3.187"	T-603A	3.312"	LA-603A	3.375"	L-603A	3.437"			6.000"
81mm	3.187"	T-603	3.312"	LA-603	3.375"	L-603	3.437"			6.500"
81mm	3.187"	T-33	3.312"	LA-33	3.375"	L-33	3.437"			7.500"
81mm	3.187"			LA-303	3.375"	L-303	3.437"			9.250"
81.5mm	3.208"	T-256	3.333"	LA-256	3.395"	L-256	3.458"			6.000"
81.5mm	3.208"	T-279	3.333"	LA-279	3.395"	L-279	3.458"			6.500"
82mm	3.228"	T-002	3.353"	LA-002	3.415"	L-002	3.478"			6.000"
82.55mm	3.250"	T-34B	3.375"	LA-34B	3.437"	L-34B	3.500"			5.500"
82.55mm	3.250"	T-34A	3.375"	LA-34A	3.437"	L-34A	3.500"			6.500"
82.55mm	3.250"	T-34	3.375"	LA-34	3.437"	L-34	3.500"			7.250"
82.55mm	3.250"	T-605	3.375"	LA-605	3.437"	L-605	3.500"			8.125"
82.55mm	3.250"			LA-304	3.437"	L-304	3.500"			9.250"

UNIVERSAL AUTOMOTIVE PROGRESSIVE SIZE LIST

L.A. SLEEVE

CYLINDER BORE		1/16" Wall		3/32" Wall		1/8" Wall		5/32" Wall		SLEEVE LENGTH
MM	IN	Part No.	O.D.	Part No.	O.D.	Part No.	O.D.	Part No.	O.D.	
83mm	3.267"	T-288	3.392"	LA-288	3.454"	L-288	3.517"			6.500"
83mm	3.267"	T-259	3.392"	LA-259	3.454"	L-259	3.517"			7.250"
83.3mm	3.279"	T-260	3.407"	LA-260	3.468"	L-260	3.530"			6.500"
83.8mm	3.300"			LA-606	3.487"	L-606	3.550"			8.250"
84mm	3.307"	T-281F	3.437"	LA-281F	3.500"	L-281F	3.562"			5.625"
84mm	3.307"	T-281	3.437"	LA-281	3.500"	L-281	3.562"			6.500"
84.1mm	3.312"	T-607V	3.437"	LA-607V	3.500"	L-607V	3.562"			5.937"
84.1mm	3.312"	T-607C	3.437"	LA-607C	3.500"	L-607C	3.562"			6.625"
84.1mm	3.312"	T-607	3.437"	LA-607	3.500"	L-607	3.562"			7.500"
84.1mm	3.312"			LA-35	3.500"	L-35	3.562"			8.000"
84.1mm	3.312"			LA-305	3.500"	L-305	3.562"			9.250"
84.91mm	3.343"			LA-62	3.531"	L-62	3.593"			7.500"
85mm	3.346"	T-270	3.471"	LA-270	3.533"	L-270	3.596"			6.187"
85mm	3.346"	T-292	3.471"	LA-292	3.533"	L-292	3.596"			6.500"
85.73mm	3.375"	T-70T	3.500"	LA-70T	3.562"	L-70T	3.625"			5.750"
85.73mm	3.375"			LA-71	3.562"	L-71	3.625"			6.000"
85.73mm	3.375"	T-70D	3.500"	LA-70D	3.562"	L-70D	3.625"			6.500"
85.73mm	3.375"	T-70	3.500"	LA-70	3.562"	L-70	3.625"			7.375"
85.73mm	3.375"			LA-700	3.562"	L-700	3.625"			8.125"
85.73mm	3.375"			LA-306	3.562"	L-306	3.625"			9.250"
86mm	3.386"	T-286	3.516"	LA-286	3.578"	L-286	3.641"			5.250"
86.3mm	3.400"	T-59A	3.525"	LA-59A	3.587"	L-59A	3.650"			6.000"
86.3mm	3.400"	T-59B	3.525"	LA-59B	3.587"	L-59B	3.650"			6.250"
86.3mm	3.400"	T-59	3.525"	LA-59	3.587"	L-59	3.650"			7.000"
87mm	3.425"	T-265C	3.562"	LA-265C	3.625"	L-265C	3.687"			6.125"
87mm	3.425"	T-265	3.562"	LA-265	3.625"	L-265	3.687"			7.125"
87.3mm	3.437"	T-38Z	3.562"							5.750"
87.3mm	3.437"	T-38	3.562"	LA-38	3.625"	L-38	3.687"			6.000"
87.3mm	3.437"	T-703	3.562"	LA-703	3.625"	L-703	3.687"			7.500"
87.3mm	3.437"			LA-701	3.625"	L-701	3.687"			8.125"
87.3mm	3.437"			LA-307	3.625"	L-307	3.687"			9.250"
87.3mm	3.437"			LA-307L	3.625"					10.000"
88mm	3.465"	T-272	3.590"	LA-272	3.642"	L-272	3.715"			6.000"
88mm	3.465"	T-272V	3.590"	LA-272V	3.642"	L-272V	3.715"			6.500"
88.5mm	3.484"	T-362	3.615"	LA-362	3.673"	L-362	3.735"			6.500"
88.9mm	3.500"	T-20A	3.625"	LA-20A	3.687"	L-20A	3.750"			5.312"
88.9mm	3.500"	T-708A	3.625"	LA-708A	3.687"	L-708A	3.750"			5.500"
88.9mm	3.500"	T-20	3.625"	LA-20	3.687"	L-20	3.750"			6.000"
88.9mm	3.500"	T-708	3.625"	LA-708	3.687"	L-708	3.750"			6.750"
88.9mm	3.500"	T-608	3.625"	LA-608	3.687"	L-608	3.750"			7.125"
88.9mm	3.500"	T-710	3.625"	LA-710	3.687"	L-710	3.750"			8.250"
88.9mm	3.500"			LA-308	3.687"	L-308	3.750"			9.250"
90mm	3.543"	T-273	3.668"	LA-273	3.730"	L-273	3.793"			6.500"
90mm	3.543"	T-273T	3.668"	LA-273T	3.730"	L-273T	3.793"			7.000"
90.2mm	3.552"			LA-372	3.740"	L-372	3.802"			6.500"
90.47mm	3.562"	T-21A	3.687"	LA-21A	3.750"	L-21A	3.812"			6.000"
90.47mm	3.562"			LA-21	3.750"	L-21	3.812"			6.687"
90.47mm	3.562"	T-608A	3.687"	LA-608A	3.750"	L-608A	3.812"			7.250"
90.47mm	3.562"			LA-704	3.750"	L-704	3.812"			7.500"
90.47mm	3.562"			LA-26	3.750"	L-26	3.812"			7.750"
90.47mm	3.562"			LA-74	3.750"	L-74	3.812"			8.000"



UNIVERSAL AUTOMOTIVE PROGRESSIVE SIZE LIST

CYLINDER BORE		1/16" Wall		3/32" Wall		1/8" Wall		5/32" Wall		SLEEVE LENGTH
MM	IN	Part No.	O.D.	Part No.	O.D.	Part No.	O.D.	Part No.	O.D.	
90.47mm	3.562"			LA-309	3.750"	L-309	3.812"			9.250"
90.93mm	3.580"	T-82	3.705"	LA-82	3.767"	L-82	3.830"			5.375"
91mm	3.582"	T-005	3.712"	LA-005	3.769"	L-005	3.832"			6.250"
92.1mm	3.625"	T-24	3.750"	LA-24	3.812"	L-24	3.875"			6.000"
92.1mm	3.625"	T-23	3.750"	LA-23	3.812"	L-23	3.875"			6.687"
92.1mm	3.625"	T-23C	3.750"	LA-23C	3.812"	L-23C	3.875"			8.000"
92.1mm	3.625"			LA-310	3.812"	L-310	3.875"	HD-310	3.937"	10.250"
92.2mm	3.630"	T-268	3.765"	LA-268	3.817"	L-268	3.880"			7.000"
92.6mm	3.646"	T-861	3.771"	LA-861	3.833"	L-861	3.895"			
93mm	3.661"			LA-85	3.848"	L-85	3.911"			6.500"
93mm	3.661"	T-359	3.786"	LA-359	3.848"	L-359	3.911"			7.000"
93.25mm	3.671"			LA-88	3.859"	L-88	3.922"			5.500"
93.65mm	3.687"	T-37A	3.812"	LA-37A	3.875"	L-37A	3.937"			5.125"
93.65mm	3.687"	T-37	3.812"	LA-37	3.875"	L-37	3.937"			6.625"
93.65mm	3.687"			LA-76	3.875"	L-76	3.937"			7.625"
93.65mm	3.687"			LA-311	3.875"	L-311	3.937"			10.250"
94mm	3.700"			LA-37D	3.887"	L-37D	3.950"			6.375"
94.44mm	3.718"			LA-27A	3.906"	L-27A	3.969"			6.250"
94.44mm	3.718"			LA-27	3.906"	L-27	3.969"			7.750"
94.9mm	3.736"			LA-87	3.922"	L-87	3.984"			6.375"
95.25mm	3.750"			LA-39A	3.937"	L-39A	4.000"			6.000"
95.25mm	3.750"			LA-39B	3.937"	L-39B	4.000"			6.125"
95.25mm	3.750"			LA-39	3.937"	L-39	4.000"			6.437"
95.25mm	3.750"			LA-44	3.937"	L-44	4.000"			7.250"
95.25mm	3.750"			LA-75	3.937"	L-75	4.000"			7.500"
95.25mm	3.750"			LA-312	3.937"	L-312	4.000"	HD-312	4.062"	10.250"
96.04mm	3.781"	T-28A	3.906"	LA-28A	3.968"	L-28A	4.031"			6.000"
96.04mm	3.781"			LA-28	3.968"	L-28	4.031"			7.750"
96.52mm	3.800"			LA-25B	3.987"	L-25B	4.050"			5.125"
96.52mm	3.800"			LA-25A	3.987"	L-25A	4.050"			6.062"
96.52mm	3.800"			LA-25	3.987"	L-25	4.050"			6.875"
96.82mm	3.812"			LA-43	4.000"	L-43	4.062"			6.625"
96.82mm	3.812"			LA-42	4.000"	L-42	4.062"			6.875"
96.82mm	3.812"			LA-77	4.000"	L-77	4.062"			7.625"
96.82mm	3.812"			LA-77A	4.000"	L-77A	4.062"			8.750"
96.82mm	3.812"			LA-313	4.000"	L-313	4.062"			10.250"
98.42mm	3.875"			LA-68	4.062"	L-68	4.125"			6.000"
98.42mm	3.875"			LA-69	4.062"	L-69	4.125"			6.375"
98.42mm	3.875"			LA-78	4.062"	L-78	4.125"			6.500"
98.42mm	3.875"			LA-707A	4.062"	L-707A	4.125"			6.750"
98.42mm	3.875"			LA-707	4.062"	L-707	4.125"			7.000"
98.42mm	3.875"			LA-702	4.062"	L-702	4.125"			7.125"
98.42mm	3.875"			LA-609	4.062"	L-609	4.125"			7.500"
98.42mm	3.875"			LA-314	4.062"	L-314	4.125"	HD-314	4.187"	10.250"
99mm	3.897"			LA-90A	4.087"	L-90A	4.150"			6.500"
99mm	3.897"			LA-90	4.087"	L-90	4.150"			7.000"
99.3mm	3.910"			LA-55	4.097"	L-55	4.160"			6.062"
100mm	3.937"			LA-47	4.125"	L-47	4.187"			6.250"
100mm	3.937"			LA-45	4.125"	L-45	4.187"			6.562"
100mm	3.937"			LA-46	4.125"	L-46	4.187"			6.875"
100mm	3.937"			LA-46G	4.125"	L-46G	4.187"			7.875"

UNIVERSAL AUTOMOTIVE PROGRESSIVE SIZE LIST

L.A. SLEEVE

CYLINDER BORE		1/16" Wall		3/32" Wall		1/8" Wall		5/32" Wall		SLEEVE LENGTH
MM	IN	Part No.	O.D.	Part No.	O.D.	Part No.	O.D.	Part No.	O.D.	
100mm	3.937"			LA-315	4.125"	L-315	4.187"			10.250"
100.3mm	3.950"			LA-006	3.137"	L-006	4.200"			6.875"
100.8mm	3.970"			LA-86	4.156"	L-86	4.218"			6.375"
101mm	3.976"			LA-862	4.163"	L-862	4.226"			6.562"
101.6mm	4.000"			LA-40B	4.187"	L-40B	4.250"			5.125"
101.6mm	4.000"	T-40	4.125"	LA-40	4.187"	L-40	4.250"			6.000"
101.6mm	4.000"			LA-40A	4.187"	L-40A	4.250"			6.250"
101.6mm	4.000"			LA-41	4.187"	L-41	4.250"			6.625"
101.6mm	4.000"			LA-49	4.187"	L-49	4.250"	HD-49	4.312"	6.875"
101.6mm	4.000"			LA-48	4.187"	L-48	4.250"			7.875"
101.6mm	4.000"			LA-400	4.187"	L-400	4.250"	HD-400	4.312"	10.250"
101.6mm	4.000"			LA-400L	4.187"	L-400L	4.250"			10.750"
102mm	4.016"	T-670	4.118"	LA-670	4.180"	L-670	4.270"			7.875"
102.4mm	4.031"			LA-72	4.218"	L-72	4.281"			7.000"
102.6mm	4.040"			LA-60	4.234"	L-60	4.297"			6.375"
103.2mm	4.062"			LA-50	4.250"	L-50	4.312"	HD-50	4.375"	6.250"
103.2mm	4.062"			LA-50B	4.250"	L-50B	4.312"			6.750"
103.2mm	4.062"			LA-401	4.250"	L-401	4.312"			10.250"
103.6mm	4.080"			LA-705	4.281"	L-705	4.343"			7.000"
104mm	4.094"			LA-36	4.281"	L-36	4.343"			6.062"
104mm	4.094"			LA-36G	4.281"	L-36G	4.343"			6.250"
104mm	4.094"			LA-61	4.281"	L-61	4.343"			6.375"
104.4mm	4.110"			LA-007	4.297"	L-007	4.360"			8.750"
104.7mm	4.125"			LA-51	4.312"	L-51	4.375"			6.312"
104.7mm	4.125"			LA-52A	4.312"	L-52A	4.375"			6.625"
104.7mm	4.125"			LA-52B	4.312"	L-52B	4.375"			6.750"
104.7mm	4.125"			LA-52	4.312"	L-52	4.375"	HD-52	4.437"	7.250"
104.7mm	4.125"			LA-52C	4.312"	L-52C	4.375"			7.500"
104.7mm	4.125"			LA-67	4.312"	L-67	4.375"			7.750"
104.7mm	4.125"			LA-402	4.312"	L-402	4.375"	HD-402	4.437"	10.250"
105mm	4.134"			LA-671	4.323"	L-671	4.386"			7.750"
105mm	4.134"	T-3163	4.240"							8.000"
105.4mm	4.150"			LA-79	4.337"	L-79	4.400"			6.250"
105.8mm	4.165"			LA-80	4.375"	L-80	4.437"			6.750"
106.3mm	4.187"			LA-57	4.375"	L-57	4.437"			7.000"
106.3mm	4.187"			LA-403	4.375"	L-403	4.437"			10.250"
106.7mm	4.200"	T-7120	4.325"	LA-7120	4.388"					8.000"
107mm	4.214"	T-3196	4.340"							8.000"
107.2mm	4.220"	T-7110	4.345"	LA-7110	4.408"	L-7110	4.470"			8.000"
107.5mm	4.234"			LA-22	4.422"	L-22	4.484"			6.250"
108mm	4.250"			LA-53A	4.437"	L-53A	4.500"			6.250"
108mm	4.250"			LA-53	4.437"	L-53	4.500"	HD-53	4.562"	6.625"
108mm	4.250"			LA-53B	4.437"	L-53B	4.500"			6.875"
108mm	4.250"			LA-63G	4.437"	L-63G	4.500"			7.000"
108mm	4.250"			LA-63	4.437"	L-63	4.500"			7.625"
108mm	4.250"			LA-63B	4.437"	L-63B	4.500"			7.760"
108mm	4.250"			LA-404	4.437"	L-404	4.500"	HD-404	4.562"	10.250"
109.2mm	4.300"			LA-54B	4.487"	L-54B	4.550"			7.000"
109.2mm	4.300"			LA-54	4.487"	L-54	4.550"			7.562"
109.5mm	4.312"			LA-58	4.500"	L-58	4.562"			7.250"
109.5mm	4.312"			LA-405	4.500"	L-405	4.562"			10.250"



UNIVERSAL AUTOMOTIVE PROGRESSIVE SIZE LIST

CYLINDER BORE		1/16" Wall		3/32" Wall		1/8" Wall		5/32" Wall		SLEEVE LENGTH
MM	IN	Part No.	O.D.	Part No.	O.D.	Part No.	O.D.	Part No.	O.D.	
109.7mm	4.320"			LA-65	4.500"	L-65	4.562"			6.750"
110mm	4.330"			LA-672	4.523"	L-672	4.585"			7.750"
110.3mm	4.342"			LA-83	4.530"	L-83	4.592"			6.250"
110.7mm	4.359"			LA-73	4.547"	L-73	4.609"			6.875"
111.1mm	4.375"			LA-66	4.562"	L-66	4.625"			7.562"
111.1mm	4.375"			LA-406	4.562"	L-406	4.625"	HD-406	4.687"	10.250"
111.7mm	4.400"	T-406A	4.505"	LA-406A	4.562"	L-406A	4.625"			7.875"
111.7mm	4.400"	T-406B	4.505"	LA-406B	4.562"	L-406B	4.625"			8.750"
112.7mm	4.437"			LA-407	4.625"	L-407	4.687"			10.250"
113mm	4.450"	T-3197	4.575"							8.000"
114.3mm	4.500"			LA-64	4.687"	L-64	4.750"			7.750"
114.3mm	4.500"					L-642	4.774"			8.000"
114.3mm	4.500"					L-645	4.804"			7.875"
114.3mm	4.500"					L-650	4.875"			8.000"
114.3mm	4.500"					L-660	5.000"			8.000"
114.3mm	4.500"			LA-640	4.687"	L-640	4.750"			8.000"
114.3mm	4.500"			LA-408	4.687"	L-408	4.750"	HD-408	4.812"	10.250"
115.8mm	4.562"			LA-409G	4.750"	L-409G	4.812"			7.625"
115.8mm	4.562"			LA-409	4.750"	L-409	4.812"			10.250"
117.47mm	4.625"			LA-410	4.812"	L-410	4.875"	HD-410	4.937"	12.250"
119.05mm	4.687"			LA-411	4.875"	L-411	4.937"			12.250"
120.65mm	4.750"			LA-412	4.937"	L-412	5.000"	HD-412	5.062"	12.250"
123.8mm	4.875"			LA-414G	5.062"	L-414G	5.125"			7.625"
123.8mm	4.875"			LA-414	5.062"	L-414	5.125"	HD-414	5.187"	12.250"
127mm	5.000"			LA-500	5.187"	L-500	5.250"	HD-500	5.312"	12.250"
130.17mm	5.125"			LA-502	5.312"	L-502	5.375"	HD-502	5.437"	12.250"
133.35mm	5.250"			LA-504	5.437"	L-504	5.500"	HD-504	5.562"	12.250"
136.52mm	5.375"			LA-506	5.562"	L-506	5.625"			12.250"
139.7mm	5.500"			LA-508	5.687"	L-508	5.750"	HD-508	5.812"	12.250"
142.9mm	5.625"			LA-510	5.812"	L-510	5.875"	HD-510	5.937"	12.250"
146mm	5.750"			LA-512	5.937"	L-512	6.000"	HD-512	6.062"	12.250"
149.22mm	5.875"			LA-514	6.062"	L-514	6.125"	HD-514	6.187"	12.250"
152.4mm	6.000"			LA-600	6.187"	L-600	6.250"	HD-600	6.312"	12.250"
155.57mm	6.125"			LA-711AP	6.312"	L-711AP	6.375"	HD-711AP	6.437"	12.125"
158.75mm	6.250"			LA-712AP	6.437"	L-712AP	6.500"	HD-712AP	6.562"	12.125"
165.1mm	6.500"			LA-713AP	6.687"	L-713AP	6.750"	HD-713AP	6.812"	12.125"
171.4mm	6.750"			LA-714AP	6.937"	L-714AP	7.000"	HD-714AP	7.062"	13.000"
177.8mm	7.000"			LA-715AP	7.187"	L-715AP	7.250"	HD-715AP	7.312"	13.000"
190.5mm	7.500"			LA-716AP	7.687"	L-716AP	7.750"			13.000"
196.8mm	7.750"			LA-717AP	7.937"	L-717AP	8.000"			13.000"
200mm	7.875"			LA-719AP	8.062"	L-719AP	8.125"			11.312"
203.2mm	8.000"			LA-718AP	8.187"	L-718AP	8.250"			13.000"
206.4mm	8.125"			LA-720AP	8.312"	L-720AP	8.375"			13.000"
209.5mm	8.250"			LA-721AP	8.437"	L-721AP	8.500"			13.000"

SLEEVE INTERCHANGE CHARTS



AE CLEVITE TO L.A. SLEEVE SUGGESTED SLEEVE INTERCHANGE

AE CLEVITE	OUR NO.	AE CLEVITE	OUR NO.	AE CLEVITE	OUR NO.	AE CLEVITE	OUR NO.	AE CLEVITE	OUR NO.
CS-101	LA-609	CS-167	LA-52C	CS-8122	L-703	US-25S	LA-314	US-55S	L-512
CS-103	LA-607	CS-173	LA-49	CS-8134	L-25	US-27F	L-400	US-57S	L-514
CS-106	LA-608	CS-178	LA-55	CS-8197	L-707	US-27LS	LA-400	US-59S	L-600
CS-109	LA-603	CS-183	LA-76	CS-8199	L-41	US-29LS	LA-402	US-61S	L-711AP
CS-110N	LA-605	CS-187	LA-50	DS-278	LA-90	US-29S	L-402	US-63S	L-712AP
CS-111	LA-608A	CS-195	LA-27	LL-89SX	L-718AP	US-30LS	LA-403	US-67S	L-713AP
CS-117N	LA-701	CS-197	LA-707	US-10S	LA-215	US-31LS	LA-404	US-6S	LA-211
CS-1191	LA-59	CS-199	LA-41	US-13S	LA-302	US-31S	L-404	US-71S	L-714AP
CS-122	LA-703	CS-204	LA-52B	US-15S	LA-304	US-32S	L-405	US-75S	L-715AP
CS-124	LA-710	CS-206	LA-80	US-16S	LA-305	US-33LS	LA-406	US-7CS	L-212
CS-132N	LA-30	CS-207	LA-53	US-17S	LA-306	US-33S	L-406	US-7S	LA-212
CS-134	LA-25	CS-208	LA-63	US-18S	LA-307	US-35S	L-408	US-83S	L-716AP
CS-136	LA-34	CS-211	LA-414G	US-19CS	L-308	US-37S	L-410	US-87S	L-717AP
CS-139	LA-23	CS-214N	LA-36G	US-19S	LA-308	US-41S	L-414	US-8S	LA-213
CS-140	LA-24	CS-8101	L-609	US-21S	LA-310	US-43S	L-500	US-9S	LA-214
CS-156	LA-44	CS-8109	L-603	US-23S	LA-312	US-45S	L-502		
CS-162	LA-68	CS-8110N	L-605	US-24S	LA-313	US-47S	L-504		
CS-165	LA-40A	CS-8117N	L-701	US-25CS	L-314	US-51S	L-508		

DANA CLEVITE TO L.A. SLEEVE SUGGESTED SLEEVE INTERCHANGE

DANA CLEVITE	OUR NO.	DANA CLEVITE	OUR NO.	DANA CLEVITE	OUR NO.	DANA CLEVITE	OUR NO.	DANA CLEVITE	OUR NO.
226-4254	LA-90	226-8030	LA-701	226-8060	LA-311	226-8101	LA-42	226-8145	LA-410
226-8002	L-302	226-8033	LA-68	226-8061	LA-312	226-8105	LA-28A	226-8147	LA-412
226-8003	L-303	226-8035	LA-44	226-8062	LA-313	226-8106	L-298	226-8150	L-502
226-8004	L-304	226-8036	LA-706	226-8063	LA-314	226-8107	LA-298	226-8151	L-504
226-8005	L-305	226-8039	LA-23	226-8064	LA-400	226-8112	L-281	226-8152	LA-208
226-8006	L-307	226-8041	LA-40A	226-8065	LA-402	226-8115	L-265C	226-8153	L-508
226-8009	L-310	226-8043	LA-55	226-8066	LA-404	226-8116	LA-265C	226-8154	L-512
226-8010	L-312	226-8044	LA-50	226-8068	LA-408	226-8123	L-86	226-8155	L-600
226-8012	L-314	226-8047	LA-40B	226-8074	LA-259	226-8124	LA-86	226-8156	L-711AP
226-8013	L-315	226-8048	LA-36G	226-8077	L-25A	226-8127	LA-281	226-8157	LA-211
226-8014	L-400	226-8049	L-36G	226-8078	LA-25A	226-8130	L-860	226-8160	LA-212
226-8015	L-402	226-8052	LA-303	226-8084	L-708A	226-8131	LA-860	226-8161	L-716AP
226-8016	L-404	226-8053	LA-304	226-8085	LA-708A	226-8132	L-245	226-8162	LA-213
226-8018	L-408	226-8054	LA-305	226-8088	L-20A	226-8133	LA-245	226-8163	L-514
226-8024	LA-609	226-8055	LA-306	226-8089	LA-20A	226-8140	LA-41		
226-8026	LA-605	226-8056	LA-307	226-8090	L-002	226-8141	L-308		
226-8027	LA-603	226-8057	LA-308	226-8091	LA-002	226-8142	LA-200		
226-8029	LA-608A	226-8059	LA-310	226-8100	L-42	226-8143	L-405		

NOTE: COMPETITIVE PART NUMBERS LISTED ARE INTERCHANGEABLE WITH OUR NUMBERS, BUT NOT NECESSARILY IDENTICAL.

ERTEL TO L.A. SLEEVE SUGGESTED SLEEVE INTERCHANGE

ERTEL	OUR NO.	ERTEL	OUR NO.	ERTEL	OUR NO.	ERTEL	OUR NO.	ERTEL	OUR NO.
SL101	LA-609	SL137	LA-49	SL2213A	L-40B	SL296	L-53	SL510	L-307
SL105	LA-603	SL138	LA-25A	SL2216	L-860	SL297	L-63G	SL511	L-308
SL106	LA-63	SL141	LA-20	SL2219	L-86	SL308F	LA-90	SL513A	L-310
SL107	LA-607	SL142	LA-23	SL2224	L-25	SL402	LA-214	SL514	L-311
SL108	LA-710	SL144	LA-24	SL2226	L-64	SL405	LA-302	SL515A	L-312
SL109	LA-608	SL145	LA-27	SL222A	L-68	SL406A	LA-303	SL516A	L-314
SL1102	LA-50B	SL150	LA-31	SL223	L-704	SL407	LA-304	SL517A	L-400
SL1105	LA-002	SL151	LA-603A	SL2231	L-298	SL408	LA-305	SL518A	L-402
SL1106	LA-88	SL152	LA-703	SL2232	L-89	SL409	LA-306	SL519A	L-404
SL1107	LA-281F	SL153	LA-33	SL2237	L-708A	SL410	LA-307	SL520A	L-405
SL1108N	LA-602	SL154N	LA-30	SL2238	L-265C	SL411	LA-308	SL521A	L-406
SL111	LA-608A	SL155	LA-59	SL2249	L-87	SL413A	LA-310	SL522A	L-408
SL1112	LA-20A	SL156	LA-59A	SL225	L-70	SL414	LA-311	SL523	L-410
SL1113A	LA-40B	SL157	LA-48	SL2252	L-862	SL415A	LA-312	SL526	L-500
SL1116	LA-860	SL161	LA-51	SL2255	L-705	SL416A	LA-314	SL527	L-407
SL1118N	LA-603C	SL162	LA-42	SL2260	L-73	SL417A	LA-400	SL528A	L-313
SL1119	LA-86	SL165	LA-707	SL2261	L-66	SL418A	LA-402	SL529A	L-315
SL1124	LA-25	SL167	LA-50	SL2274	L-007	SL419A	LA-404	SL532A	L-403
SL1126	LA-64	SL168	LA-409G	SL230	L-52B	SL420A	LA-405	SL550	L-200
SL113	LA-414G	SL169	LA-83	SL233	L-69	SL421A	LA-406	SL554	L-204
SL1131	LA-298	SL170	LA-706A	SL235	L-706	SL422A	LA-408	SL556	L-206
SL1132	LA-89	SL173	LA-28A	SL236	L-40A	SL423	LA-410	SL557	L-207
SL1137	LA-708A	SL179	LA-36G	SL237	L-49	SL427	LA-407	SL558	L-208
SL1138	LA-265C	SL180	LA-41	SL238	L-25A	SL428A	LA-313	SL559	L-209
SL1142	LA-34	SL182	LA-78	SL241	L-20	SL429A	LA-315	SL560	L-210
SL1149	LA-87	SL186	LA-80	SL242	L-23	SL432A	LA-403	SL561	L-211
SL1152	LA-862	SL187	LA-54	SL244	L-24	SL450	LA-200	SL562	L-213
SL1155	LA-705	SL196	LA-53	SL250	L-31	SL454	LA-204	SL565	L-412
SL115N	LA-605	SL197	LA-63G	SL252	L-703	SL456	LA-206	SL585	L-212
SL116	LA-55	SL201	L-609	SL253	L-33	SL457	LA-207	SL589	L-401
SL1160	LA-73	SL205	L-603	SL254N	L-30	SL458	LA-208	SL604A	LA-56
SL1161	LA-66	SL206	L-63	SL255	L-59	SL459	LA-209	SL605A	LA-245
SL1174	LA-007	SL207	L-607	SL257	L-48	SL460	LA-210	SL609	LA-254
SL118	LA-79	SL209	L-608	SL261	L-51	SL461	LA-211	SL614	LA-272
SL119N	LA-701	SL211	L-608A	SL262	L-42	SL462	LA-213	SL626	LA-85
SL120	LA-44	SL213	L-414G	SL265	L-707	SL463	LA-215	SL704A	L-56
SL121	LA-65	SL215N	L-605	SL267	L-50	SL465	LA-412	SL705A	L-245
SL122A	LA-68	SL216	L-55	SL268	L-409G	SL485	LA-212	SL709	L-254
SL123	LA-704	SL219N	L-701	SL269	L-83	SL489	LA-401	SL726	L-85
SL125	LA-70	SL2202	L-50B	SL273	L-28A	SL505	L-302	SL803	LA-259
SL130	LA-52B	SL2205	L-002	SL279	L-36G	SL506A	L-303		
SL133	LA-69	SL2206	L-88	SL280	L-41	SL507	L-304		
SL135	LA-706	SL221	L-65	SL286	L-80	SL508	L-305		
SL136	LA-40A	SL2212	L-20A	SL287	L-54	SL509	L-306		

NOTE: COMPETITIVE PART NUMBERS LISTED ARE INTERCHANGEABLE WITH OUR NUMBERS, BUT NOT NECESSARILY IDENTICAL.

SLEEVE INTERCHANGE CHARTS



FEDERAL-MOGUL TO L.A. SLEEVE SUGGESTED SLEEVE INTERCHANGE

FEDERAL-MOGUL	OUR NO.	FEDERAL-MOGUL	OUR NO.	FEDERAL-MOGUL	OUR NO.	FEDERAL-MOGUL	OUR NO.	FEDERAL-MOGUL	OUR NO.
SL10M	LA-303	SL14Y	L-307	SL191M	LA-21A	SL20Y	L-314	SL26M	LA-408
SL10Y	L-303	SL15M	LA-308	SL192M	LA-55	SL215M	LA-405	SL26Y	L-408
SL113M	LA-701	SL15Y	L-308	SL195M	LA-23	SL215Y	L-405	SL28Y	L-500
SL11M	LA-304	SL173M	LA-90	SL196M	LA-40A	SL22M	LA-400	SL41Y	L-414
SL11Y	L-304	SL178M	LA-68	SL199M	LA-59	SL22Y	L-400	SL70Y	L-410
SL123M	LA-605	SL179M	LA-24	SL19M	LA-312	SL23M	LA-402	SL78M	LA-608
SL12M	LA-305	SL17M	LA-310	SL19Y	L-312	SL23Y	L-402	SL7M	LA-300
SL12Y	L-305	SL17Y	L-310	SL200M	LA-706A	SL24M	LA-404	SL93M	LA-313
SL137M	LA-704	SL180M	LA-268	SL201M	LA-31	SL24Y	L-404	SL94M	LA-608A
SL13M	LA-306	SL18M	LA-311	SL205M	LA-51	SL25M	LA-406	SL9M	LA-302
SL14M	LA-307	SL190M	LA-49	SL20M	LA-314	SL25Y	L-406		

LERC TO L.A. SLEEVE SUGGESTED SLEEVE INTERCHANGE

LERC	OUR NO.	LERC	OUR NO.	LERC	OUR NO.	LERC	OUR NO.	LERC	OUR NO.
C-10	LA-608	C-207	L-20	C-346	L-23	C-78	LA-54	C-956	LA-80
C-104	LA-31	C-21	L-706	C-350	LA-88	C-79	L-54	C-957	L-80
C-105	L-31	C-212	LA-706A	C-351	L-88	C-82	LA-27	C-96	LA-40A
C-106	LA-21A	C-213	L-706A	C-376	LA-28A	C-83	L-27	C-960	LA-53A
C-107	L-21A	C-218	LA-69	C-377	L-28A	C-928	LA-41	C-961	L-53A
C-11	L-608	C-219	L-69	C-386	LA-25	C-929	L-41	C-964	LA-53
C-12	LA-608A	C-228	LA-55	C-387	L-25	C-930	LA-49	C-965	L-53
C-124	LA-50	C-229	L-55	C-392	LA-42	C-931	L-49	C-966	LA-63G
C-125	L-50	C-230	LA-268	C-393	L-42	C-938	LA-50B	C-967	L-63G
C-128	LA-20A	C-231	L-268	C-398	LA-78	C-939	L-50B	C-968	LA-63
C-129	L-20A	C-26N	LA-701	C-399	L-78	C-94	LA-25A	C-969	L-63
C-13	L-608A	C-290	LA-607	C-40	LA-48	C-942	LA-36	C-97	L-40A
C-152	LA-707	C-291	L-607	C-41	L-48	C-943	L-36	C-974	LA-65
C-153	L-707	C-30	LA-39A	C-42	LA-51	C-946	LA-52A	C-975	L-65
C-168	LA-59A	C-302	LA-59	C-43	L-51	C-947	L-52A	C-976	LA-83
C-169	L-59A	C-303	L-59	C-52	LA-603	C-948	LA-52B	C-977	L-83
C-20	LA-706	C-31	L-39A	C-53	L-603	C-949	L-52B	C-988	LA-414G
C-202	LA-24	C-32	LA-44	C-60	LA-606	C-95	L-25A	C-989	L-414G
C-203	L-24	C-33	L-44	C-61	L-606	C-950	LA-79	C-994	LA-002
C-206	LA-20	C-346	LA-23	C-64	LA-609	C-951	L-79	C-995	L-002

NOTE: COMPETITIVE PART NUMBERS LISTED ARE INTERCHANGEABLE WITH OUR NUMBERS, BUT NOT NECESSARILY IDENTICAL.

MANLEY BADGER TO L.A. SLEEVE SUGGESTED SLEEVE INTERCHANGE

MANLEY BADGER	OUR NO.	MANLEY BADGER	OUR NO.	MANLEY BADGER	OUR NO.	MANLEY BADGER	OUR NO.	MANLEY BADGER	OUR NO.
SL10	LA-608	SL301	L-707	SL387	L-87	SL472	LA-89	SL643	LA-314
SL11	L-608	SL306	LA-41	SL388	LA-73	SL473	L-89	SL644	L-314
SL12	LA-608A	SL307	L-41	SL392	LA-298	SL503	LA-209	SL646	LA-400
SL120	LA-607	SL318	LA-80	SL393	L-298	SL506	LA-211	SL647	L-400
SL121	L-607	SL319	L-80	SL404N	LA-30	SL507	L-211	SL649	LA-402
SL138-1	LA-69	SL326	LA-25	SL405N	L-30	SL509	LA-213	SL65	L-609
SL139-1	L-69	SL327	L-25	SL408	LA-708A	SL510	L-213	SL650	L-402
SL142	LA-703	SL328	LA-54	SL409	L-708A	SL512	LA-215	SL653	LA-403
SL143	L-703	SL329	L-54	SL422	LA-25A	SL519	L-315	SL655	LA-404
SL144	LA-704	SL334N	LA-36G	SL423	L-25A	SL52	LA-603	SL656	L-404
SL145	L-704	SL335N	L-36G	SL424	LA-86	SL53	L-603	SL657	L-405
SL150	LA-31	SL342	LA-409G	SL425	L-86	SL56F	LA-90	SL659	LA-406
SL16	LA-44	SL343	L-409G	SL426	LA-88	SL595	LA-212	SL660	L-406
SL17	L-44	SL344	LA-78	SL427	L-88	SL596	L-212	SL662	L-407
SL18	LA-68	SL346	LA-50B	SL430	LA-705	SL598	LA-214	SL664	L-408
SL20	LA-706	SL347	L-50B	SL431	L-705	SL607	LA-302	SL668	L-410
SL21	L-706	SL348	LA-52C	SL432	LA-245	SL608	L-302	SL674	L-500
SL22N	LA-605	SL349	L-52C	SL433	L-245	SL610	LA-303	SL711	LA-002
SL23N	L-605	SL350	LA-64	SL436	LA-24	SL613	LA-304	SL712N	LA-603C
SL244	LA-53	SL358	LA-63G	SL437	L-24	SL614	L-304	SL717	L-65
SL245	L-53	SL359	L-63G	SL439	L-20A	SL616	LA-305	SL718	L-50
SL246	LA-52B	SL36	LA-55	SL442	LA-860	SL617	L-305	SL719	L-311
SL247	L-52B	SL360	LA-83	SL443	L-860	SL619	LA-306	SL72	LA-23
SL252	LA-603A	SL361	L-83	SL447	L-002	SL622	LA-307	SL720	LA-311
SL256	LA-59	SL364	LA-28A	SL450	LA-265C	SL623	L-307	SL721	LA-59A
SL257	L-59	SL365	L-28A	SL451	L-265C	SL625	LA-308	SL722	LA-50
SL262	LA-27	SL366	LA-66	SL454	LA-862	SL626	L-308	SL723	LA-706A
SL26N	LA-701	SL367	L-66	SL455	L-862	SL631	LA-310	SL73	L-23
SL272	LA-63	SL368	LA-414G	SL464	LA-85	SL632	L-310	SL74	LA-20
SL273	L-63	SL37	L-55	SL465	L-85	SL637	LA-312	SL803	LA-259
SL27N	L-701	SL372	LA-79	SL466	LA-007	SL638	L-312	SL90	LA-49
SL280	LA-76	SL376N	LA-602	SL467	L-007	SL64	LA-609	SL91	L-49
SL294	LA-40A	SL378	LA-34	SL468	LA-56	SL640	LA-313		
SL300	LA-707	SL386	LA-87	SL469	L-56	SL641	L-313		

NOTE: COMPETITIVE PART NUMBERS LISTED ARE INTERCHANGEABLE WITH OUR NUMBERS, BUT NOT NECESSARILY IDENTICAL.

SLEEVE INTERCHANGE CHART



MELLING TO L.A. SLEEVE SUGGESTED SLEEVE INTERCHANGE

MELLING	OUR NO.	MELLING	OUR NO.	MELLING	OUR NO.	MELLING	OUR NO.	MELLING	OUR NO.
CSL101	LA-609	CSL1161	LA-66	CSL169	LA-83	CSL223	L-704	CSL253	L-33
CSL105	LA-603	CSL1165	LA-37A	CSL170	LA-706A	CSL2231	L-298	CSL254N	L-30
CSL106	LA-63	CSL1168	LA-31C	CSL172	LA-52A	CSL2232	L-89	CSL255	L-59
CSL107	LA-607	CSL1169	LA-706V	CSL173	LA-28A	CSL2237	L-708A	CSL256	L-59A
CSL108	LA-710	CSL1170	LA-40	CSL179	LA-36	CSL2238	L-265C	CSL257	L-48
CSL109	LA-608	CSL1174	LA-007	CSL180	LA-41	CSL2242	L-34	CSL258	L-21A
CSL1102	LA-50B	CSL1176	LA-406B	CSL182	LA-78	CSL2244	L-62	CSL261	L-51
CSL1105	LA-002	CSL1179N	LA-36G	CSL186	LA-80	CSL2245	L-71	CSL262	L-42
CSL1106	LA-88	CSL118	LA-79	CSL187	LA-54	CSL2246	L-38	CSL265	L-707
CSL1107	LA-281F	CSL119N	LA-701	CSL196	LA-53	CSL2248	L-76	CSL267	L-50
CSL1108N	LA-602	CSL120	LA-44	CSL197	LA-63G	CSL2249	L-87	CSL268	L-409G
CSL111	LA-608A	CSL121	LA-65	CSL199	LA-53A	CSL225	L-70	CSL269	L-83
CSL1112	LA-20A	CSL122A	LA-68	CSL201	L-609	CSL2251	L-46	CSL270	L-706A
CSL1113A	LA-40B	CSL123	LA-704	CSL205	L-603	CSL2252	L-862	CSL272	L-52A
CSL1116	LA-860	CSL125	LA-70	CSL206	L-63	CSL2254	L-72	CSL273	L-28A
CSL1118N	LA-603C	CSL130	LA-52B	CSL207	L-607	CSL2255	L-705	CSL279	L-36
CSL1119	LA-86	CSL133	LA-69	CSL208	L-710	CSL2256	L-52C	CSL280	L-41
CSL112	LA-606	CSL134	LA-268	CSL209	L-608	CSL2258	L-22	CSL282	L-78
CSL1124	LA-25	CSL135	LA-706	CSL211	L-608A	CSL2260	L-73	CSL286	L-80
CSL1126	LA-64	CSL136	LA-40A	CSL212	L-606	CSL2261	L-66	CSL287	L-54
CSL1128	LA-281	CSL137	LA-49	CSL213	L-414G	CSL2265	L-37A	CSL296	L-53
CSL113	LA-414G	CSL138	LA-25A	CSL215N	L-605	CSL2268	L-31C	CSL297	L-63G
CSL1131	LA-298	CSL139	LA-39A	CSL216	L-55	CSL2269	L-706V	CSL299	L-53A
CSL1132	LA-89	CSL141	LA-20	CSL218	L-79	CSL2274	L-007	CSL308F	LA-90
CSL1137	LA-708A	CSL142	LA-23	CSL219N	L-701	CSL2276	L-406B	CSL402	LA-214
CSL1138	LA-265C	CSL144	LA-24	CSL220	L-44	CSL2279N	L-36G	CSL403	LA-300
CSL1142	LA-34	CSL145	LA-27	CSL2202	L-50B	CSL230	L-52B	CSL404	LA-301
CSL1144	LA-62	CSL150	LA-31	CSL2205	L-002	CSL233	L-69	CSL405	LA-302
CSL1145	LA-71	CSL151	LA-603A	CSL2206	L-88	CSL234	L-268	CSL406A	LA-303
CSL1146	LA-38	CSL152	LA-703	CSL2207	L-281F	CSL235	L-706	CSL407	LA-304
CSL1148	LA-76	CSL153	LA-33	CSL2208N	L-602	CSL236	L-40A	CSL408	LA-305
CSL1149	LA-87	CSL154N	LA-30	CSL221	L-65	CSL237	L-49	CSL409	LA-306
CSL1151	LA-46	CSL155	LA-59	CSL2212	L-20A	CSL238	L-25A	CSL410	LA-307
CSL1152	LA-862	CSL156	LA-59A	CSL2213A	L-40B	CSL239	L-39A	CSL411	LA-308
CSL1154	LA-72	CSL157	LA-48	CSL2216	L-860	CSL241	L-20	CSL413A	LA-310
CSL1155	LA-705	CSL158	LA-21A	CSL2218N	L-603C	CSL242	L-23	CSL414	LA-311
CSL1156	LA-52C	CSL161	LA-51	CSL2219	L-86	CSL244	L-24	CSL415A	LA-312
CSL1158	LA-22	CSL162	LA-42	CSL2224	L-25	CSL245	L-27	CSL416A	LA-314
CSL115N	LA-605	CSL165	LA-707	CSL2226	L-64	CSL250	L-31	CSL417A	LA-400
CSL116	LA-55	CSL167	LA-50	CSL2228	L-281	CSL251	L-603A	CSL418A	LA-402
CSL1160	LA-73	CSL168	LA-409G	CSL222A	L-68	CSL252	L-703	CSL419A	LA-404

NOTE: COMPETITIVE PART NUMBERS LISTED ARE INTERCHANGEABLE WITH OUR NUMBERS, BUT NOT NECESSARILY IDENTICAL.



SLEEVE INTERCHANGE CHART

MELLING TO L.A. SLEEVE SUGGESTED SLEEVE INTERCHANGE (cont'd)

MELLING	OUR NO.	MELLING	OUR NO.	MELLING	OUR NO.	MELLING	OUR NO.	MELLING	OUR NO.
CSL420A	LA-405	CSL465	LA-412	CSL526	L-500	CSL570	L-508	CSL620	LA-214A
CSL421A	LA-406	CSL485	LA-212	CSL527	L-407	CSL571	L-510	CSL622	LA-238F
CSL422A	LA-408	CSL489	LA-401	CSL528A	L-313	CSL572	L-512	CSL625	LA-005
CSL423	LA-410	CSL502	L-214	CSL529A	L-315	CSL573	L-514	CSL626	LA-85
CSL426	LA-500	CSL503	L-300	CSL531	L-409	CSL574	L-600	CSL628	LA-291A
CSL427	LA-407	CSL504	L-301	CSL532A	L-403	CSL575	L-711AP	CSL629	LA-248
CSL428A	LA-313	CSL505	L-302	CSL550	L-200	CSL576	L-712AP	CSL633	LA-232
CSL429A	LA-315	CSL506A	L-303	CSL551	L-201	CSL577	L-713AP	CSL634	LA-274
CSL431	LA-409	CSL507	L-304	CSL552	L-202	CSL578	L-714AP	CSL704A	L-56
CSL432A	LA-403	CSL508	L-305	CSL553	L-203	CSL579	L-715AP	CSL705A	L-245
CSL450	LA-200	CSL509	L-306	CSL554	L-204	CSL581	L-716AP	CSL707	L-214F
CSL451	LA-201	CSL510	L-307	CSL555	L-205	CSL582	L-717AP	CSL708	L-362
CSL452	LA-202	CSL511	L-308	CSL556	L-206	CSL583	L-718AP	CSL709	L-254
CSL453	LA-203	CSL513A	L-310	CSL557	L-207	CSL585	L-212	CSL711	L-288
CSL454	LA-204	CSL514	L-311	CSL558	L-208	CSL589	L-401	CSL714	L-272
CSL455	LA-205	CSL515A	L-312	CSL559	L-209	CSL604A	LA-56	CSL716	L-276
CSL456	LA-206	CSL516A	L-314	CSL560	L-210	CSL605A	LA-245	CSL717	L-270
CSL457	LA-207	CSL517A	L-400	CSL561	L-211	CSL607	LA-214F	CSL719	L-255
CSL458	LA-208	CSL518A	L-402	CSL562	L-213	CSL608	LA-362	CSL720	L-214A
CSL459	LA-209	CSL519A	L-404	CSL563	L-215	CSL609	LA-254	CSL722	L-238F
CSL460	LA-210	CSL520A	L-405	CSL564	L-411	CSL611	LA-288	CSL726	L-85
CSL461	LA-211	CSL521A	L-406	CSL565	L-412	CSL614	LA-272	CSL728	L-291A
CSL462	LA-213	CSL522A	L-408	CSL567	L-502	CSL616	LA-276	CSL729	L-248
CSL463	LA-215	CSL523	L-410	CSL568	L-504	CSL617	LA-270	CSL803	LA-259
CSL464	LA-411	CSL525	L-414	CSL569	L-506	CSL619	LA-255	CSL903	L-259

NAPA TO L.A. SLEEVE SUGGESTED SLEEVE INTERCHANGE

NAPA	OUR NO.	NAPA	OUR NO.	NAPA	OUR NO.	NAPA	OUR NO.	NAPA	OUR NO.
226-4254	LA-90	226-8016	L-404	226-8043	LA-55	226-8060	LA-311	226-8085	LA-708A
226-8002	L-302	226-8018	L-408	226-8044	LA-50	226-8061	LA-312	226-8088	L-20A
226-8003	L-303	226-8024	LA-609	226-8047	LA-40B	226-8062	LA-313	226-8089	LA-20A
226-8004	L-304	226-8026	LA-605	226-8048	LA-36G	226-8063	LA-314	226-8090	L-002
226-8005	L-305	226-8027	LA-603	226-8049	L-36G	226-8064	LA-400	226-8091	LA-002
226-8006	L-307	226-8029	LA-608A	226-8052	LA-303	226-8065	LA-402	226-8100	L-42
226-8009	L-310	226-8030	LA-701	226-8053	LA-304	226-8066	LA-404	226-8101	LA-42
226-8010	L-312	226-8033	LA-68	226-8054	LA-305	226-8068	LA-408	226-8105	LA-28A
226-8012	L-314	226-8035	LA-44	226-8055	LA-306	226-8074	LA-259	226-8106	L-298
226-8013	L-315	226-8036	LA-706	226-8056	LA-307	226-8077	L-25A	226-8107	LA-298
226-8014	L-400	226-8039	LA-23	226-8057	LA-308	226-8078	LA-25A	226-8112	L-281
226-8015	L-402	226-8041	LA-40A	226-8059	LA-310	226-8084	L-708A	226-8115	L-265C

NOTE: COMPETITIVE PART NUMBERS LISTED ARE INTERCHANGEABLE WITH OUR NUMBERS, BUT NOT NECESSARILY IDENTICAL.

SLEEVE INTERCHANGE CHART



NAPA TO L.A. SLEEVE SUGGESTED SLEEVE INTERCHANGE (cont'd)

NAPA	OUR NO.	NAPA	OUR NO.	NAPA	OUR NO.	NAPA	OUR NO.	NAPA	OUR NO.
226-8116	LA-265C	226-8132	L-245	226-8145	LA-410	226-8154	L-512	226-8162	LA-213
226-8123	L-86	226-8133	LA-245	226-8147	LA-412	226-8155	L-600	226-8163	L-514
226-8124	LA-86	226-8140	LA-41	226-8150	L-502	226-8156	L-711AP		
226-8127	LA-281	226-8141	L-308	226-8151	L-504	226-8157	LA-211		
226-8130	L-860	226-8142	LA-200	226-8152	LA-208	226-8160	LA-212		
226-8131	LA-860	226-8143	L-405	226-8153	L-508	226-8161	L-716AP		

RAMSCO TO L.A. SLEEVE SUGGESTED SLEEVE INTERCHANGE

RAMSCO	OUR NO.	RAMSCO	OUR NO.	RAMSCO	OUR NO.	RAMSCO	OUR NO.	RAMSCO	OUR NO.
A102	LA-22	A337	LA-245	A60N	LA-30	B194	L-50B	B42	L-607
A103	LA-62	A338	LA-276	A62	LA-704	B197	L-63	B43	L-608
A104	LA-90	A339	LA-56	A63	LA-34	B227	L-41	B44	L-608A
A106	LA-66	A34	LA-609	A64	LA-306	B234	L-707	B465	L-409G
A108	LA-73	A348	LA-298	A66N	LA-602	B246	L-76	B477	L-40B
A110	LA-83	A35	LA-606	A70	LA-304	B248	L-706V	B47N	L-701
A111	LA-79	A36	LA-608A	A777	LA-40A	B253	L-214A	B48	L-706
A112	LA-705	A366	LA-255	A78	LA-44	B280	L-28A	B497	L-53
A134	LA-314	A377	LA-49	A86	LA-78	B292	L-52B	B50	L-281
A140	LA-59	A38	LA-87	A88	LA-88	B32	L-86	B54	L-24
A141	LA-38	A39	LA-862	A89	LA-55	B321	L-238F	B55	L-25
A142	LA-68	A397	LA-53A	A91	LA-46	B333	L-20A	B56	L-603
A145	LA-706A	A399	LA-64	A93	LA-72	B336	L-002	B57	L-23
A147	LA-703	A40	LA-59A	A94	LA-401	B337	L-245	B58	L-71
A151	LA-21A	A41N	LA-605	A95	LA-80	B338	L-276	B60N	L-30
A154	LA-268	A42	LA-607	A96	LA-54	B339	L-56	B62	L-704
A155	LA-42	A43	LA-608	B102	L-22	B34	L-609	B63	L-34
A156	LA-603A	A465	LA-409G	B103	L-62	B340	L-270	B66N	L-602
A181	LA-27	A466	LA-414G	B106	L-66	B341	L-281F	B70	L-304
A192	LA-52C	A477	LA-40B	B110	L-83	B348	L-298	B78	L-44
A194	LA-50B	A47N	LA-701	B111	L-79	B35	L-606	B81	L-27
A197	LA-63	A48	LA-706	B112	L-705	B356N	L-603C	B86	L-78
A234	LA-707	A497	LA-53	B140	L-59	B362	L-272	B88	L-88
A246	LA-76	A50	LA-281	B141	L-38	B364	L-259	B89	L-55
A248	LA-706V	A52	LA-209	B142	L-68	B366	L-255	B91	L-46
A253	LA-214A	A54	LA-24	B145	L-706A	B377	L-49	B93	L-72
A280	LA-28A	A55	LA-25	B147	L-703	B38	L-87	B94	L-401
A292	LA-52B	A56	LA-603	B151	L-21A	B39	L-862	B95	L-80
A31	LA-710	A57	LA-23	B154	L-268	B397	L-53A	B96	L-54
A32	LA-86	A58	LA-71	B156	L-603A	B40	L-59A	P08A	L-201
A321	LA-238F	A59	LA-31	B192	L-52C	B41N	L-605	P108A	L-310

NOTE: COMPETITIVE PART NUMBERS LISTED ARE INTERCHANGEABLE WITH OUR NUMBERS, BUT NOT NECESSARILY IDENTICAL.

RAMSCO TO L.A. SLEEVE SUGGESTED SLEEVE INTERCHANGE (cont'd)

RAMSCO	OUR NO.	RAMSCO	OUR NO.	RAMSCO	OUR NO.	RAMSCO	OUR NO.	RAMSCO	OUR NO.
P108B	L-312	P168A	L-409	P218	L-502	P378	L-716AP	P68	L-305
P108C	L-313	P169	LA-400	P228	L-504	P38	L-302	P69	LA-303
P109	LA-307	P178	L-410	P238	L-506	P388	L-717AP	P8	L-215
P118	L-314	P178A	L-411	P248	L-508	P39	LA-300	P808A	L-211
P118A	L-315	P179	LA-402	P258	L-510	P398	L-718AP	P809A	LA-211
P119	LA-308	P179A	LA-403	P268	L-512	P408	L-202	P88	L-307
P128	L-400	P18	L-300	P278	L-514	P408A	L-203	P89	LA-305
P138	L-402	P188	L-412	P28	L-301	P409	LA-202	P8A	L-214
P139	LA-310	P189	LA-404	P288	L-600	P409A	LA-203	P8AA	L-213
P148	L-404	P19	LA-214	P29	LA-215	P49	LA-301	P8B	L-212
P148A	L-405	P198	L-414	P298JD	L-711AP	P508A	L-205	P9	LA-212
P149	LA-312	P199	LA-406	P308	L-712AP	P509A	LA-205	P90A	LA-201
P149A	LA-313	P208	L-500	P328	L-713AP	P59	LA-302	P98	L-308
P158	L-406	P209A	LA-409	P348JD	L-714AP	P608A	L-207	P9A	LA-213
P168	L-408	P209C	LA-411	P358	L-715AP	P609	LA-206		

SEALED POWER TO L.A. SLEEVE SUGGESTED SLEEVE INTERCHANGE

SEALED POWER	OUR NO.	SEALED POWER	OUR NO.	SEALED POWER	OUR NO.	SEALED POWER	OUR NO.	SEALED POWER	OUR NO.
SL-10M	LA-303	SL-14Y	L-307	SL-192M	LA-55	SL-22Y	L-400	SL-41Y	L-414
SL-10Y	L-303	SL-15M	LA-308	SL-195M	LA-23	SL-23M	LA-402	SL-604F	LA-214
SL113M	LA-701	SL-15Y	L-308	SL-196M	LA-40A	SL-23Y	L-402	SL-70M	LA-410
SL-11M	LA-304	SL-173M	LA-90	SL-199M	LA-59	SL-24M	LA-404	SL-70Y	L-410
SL-11Y	L-304	SL-178M	LA-68	SL-19M	LA-312	SL-24Y	L-404	SL-78M	LA-608
SL-123M	LA-605	SL-179M	LA-24	SL-19Y	L-312	SL-25M	LA-406	SL-93M	LA-313
SL-12M	LA-305	SL-17M	LA-310	SL-200M	LA-706A	SL-25Y	L-406	SL-94M	LA-608A
SL-12Y	L-305	SL-17Y	L-310	SL-201M	LA-31	SL-26M	LA-408	SL-9M	LA-302
SL-137M	LA-704	SL-180M	LA-268	SL-20M	LA-314	SL-26Y	L-408		
SL-13M	LA-306	SL-18M	LA-311	SL-20Y	L-314	SL-27Y	L-412		
SL-140M	LA-603	SL-190M	LA-49	SL-215Y	L-405	SL-28Y	L-500		
SL-14M	LA-307	SL-191M	LA-21A	SL-22M	LA-400	SL-383M	LA-40B		

NOTE: COMPETITIVE PART NUMBERS LISTED ARE INTERCHANGEABLE WITH OUR NUMBERS, BUT NOT NECESSARILY IDENTICAL.

SLEEVE INTERCHANGE CHART



TIGER POWER TO L.A. SLEEVE SUGGESTED SLEEVE INTERCHANGE

TIGER POWER	OUR NO.	TIGER POWER	OUR NO.	TIGER POWER	OUR NO.	TIGER POWER	OUR NO.	TIGER POWER	OUR NO.
TP153	LA-608	TP191	LA-59	TP239	LA-66	TP297	L-265C	TP349	L-307
TP154	L-608	TP192	L-59	TP240	L-66	TP300	LA-862	TP350	LA-308
TP155	LA-608A	TP194	LA-27	TP241	LA-414G	TP301	L-862	TP351	L-308
TP156	LA-44	TP195	LA-63	TP244	LA-79	TP310	LA-85	TP354	LA-310
TP157	L-44	TP196	L-63	TP245	LA-34	TP311	L-85	TP355	L-310
TP158	LA-68	TP199	LA-40A	TP246	LA-710	TP312	LA-007	TP356	LA-312
TP159	LA-706	TP200	LA-707	TP247	LA-87	TP313	L-007	TP357	L-312
TP160	L-706	TP201	L-707	TP248	L-87	TP314	LA-56	TP358	LA-313
TP161	LA-55	TP204	LA-41	TP249	LA-73	TP315	L-56	TP359	L-313
TP162	L-55	TP205	L-41	TP250	L-73	TP318	LA-89	TP360	LA-314
TP163	LA-603	TP206	LA-40B	TP252	LA-298	TP319	L-89	TP361	L-314
TP164	L-603	TP207	L-40B	TP253	L-298	TP324	L-207	TP362	LA-400
TP165	LA-609	TP210	LA-80	TP258	LA-708A	TP325	LA-209	TP363	L-400
TP166	L-609	TP211	L-80	TP259	L-708A	TP326	LA-211	TP364	LA-402
TP167	LA-23	TP214	LA-25	TP270	LA-42	TP327	L-211	TP365	L-402
TP168	L-23	TP215	L-25	TP271	L-42	TP328	LA-213	TP366	LA-401
TP169	LA-20	TP216	LA-54	TP272	LA-86	TP329	L-213	TP367	L-401
TP173	LA-49	TP-216-2	L-54	TP273	L-86	TP330	LA-215	TP368	LA-403
TP174	L-49	TP221	LA-409G	TP274	LA-88	TP331	L-315	TP369	LA-404
TP176	LA-607	TP222	L-409G	TP275	L-88	TP332	LA-206	TP370	L-404
TP177	L-607	TP223	LA-78	TP278	LA-705	TP335	LA-212	TP371	L-405
TP178	LA-69	TP224	LA-50B	TP279	L-705	TP336	L-212	TP372	LA-406
TP179	L-69	TP225	L-50B	TP280	LA-245	TP337	LA-214	TP373	L-406
TP180	LA-703	TP226	LA-64	TP281	L-245	TP340	LA-302	TP375	L-408
TP181	L-703	TP229	LA-65	TP284	LA-24	TP341	L-302	TP376	L-410
TP182	LA-704	TP230	L-65	TP285	L-24	TP342	LA-303	TP377	L-412
TP183	L-704	TP233	LA-63G	TP286	L-20A	TP343	LA-304	TP378	L-500
TP186	LA-53	TP234	L-63G	TP289	LA-860	TP344	L-304	TP411F	LA-90
TP187	L-53	TP235	LA-83	TP290	L-860	TP345	LA-305		
TP188	LA-52B	TP236	L-83	TP293	L-002	TP346	L-305		
TP189	L-52B	TP237	LA-28A	TP293-1	LA-002	TP347	LA-306		
TP190	LA-603A	TP238	L-28A	TP296	LA-265C	TP348	LA-307		

NOTE: COMPETITIVE PART NUMBERS LISTED ARE INTERCHANGEABLE WITH OUR NUMBERS, BUT NOT NECESSARILY IDENTICAL.

VERSNICK TO L.A. SLEEVE SUGGESTED SLEEVE INTERCHANGE

VERSNICK	OUR NO.	VERSNICK	OUR NO.	VERSNICK	OUR NO.	VERSNICK	OUR NO.	VERSNICK	OUR NO.
S102	LA-603	S205	L-302	S33-1	L-25	A197	LA-63	A60N	LA-30
S103	LA-609	S207	L-304	S335	LA-313	A234	LA-707	A62	LA-704
S103-1	LA-707	S208	L-305	S339	LA-401	A246	LA-76	A63	LA-34
S103-2	LA-78	S21	L-706	S340	LA-403	A248	LA-706V	A64	LA-306
S105N	LA-605	S210	L-307	S345-1	LA-409G	A253	LA-214A	A66N	LA-602
S106N	LA-607	S213	L-310	S52	L-23	A280	LA-28A	A70	LA-304
S108	LA-608	S215	L-312	S58	L-49	A292	LA-52B	A777	LA-40A
S110	LA-608A	S216	L-314	S5N	L-605	A31	LA-710	A78	LA-44
S114N	LA-701	S217	L-400	S61	L-52B	A32	LA-86	A86	LA-78
S115	LA-704	S218	L-402	S67	L-44	A321	LA-238F	A88	LA-88
S121	LA-706	S219	L-404	S6N	L-607	A337	LA-245	A89	LA-55
S126	LA-34	S220	L-406	S73	L-50B	A338	LA-276	A91	LA-46
S128	LA-710	S221	L-408	S74	L-55	A339	LA-56	A93	LA-72
S129-1	LA-27	S222	L-405	S8	L-608	A34	LA-609	A94	LA-401
S133-1	LA-25	S222-1	L-65	S81	LA-28A	A348	LA-298	A95	LA-80
S140	LA-31	S223	L-410	S83	L-80	A35	LA-606	A96	LA-54
S149	LA-603A	S224	L-412	S86	L-63	A36	LA-608A	B102	L-22
S14N	L-701	S226	L-500	S87	L-59	A366	LA-255	B103	L-62
S15	L-704	S235	L-313	S88	L-63G	A377	LA-49	B106	L-66
S150	LA-20	S239	L-401	S92-1	L-40B	A38	LA-87	B110	L-83
S152	LA-23	S241	L-315	A102	LA-22	A39	LA-862	B111	L-79
S154	LA-69	S245-1	L-409G	A103	LA-62	A397	LA-53A	B112	L-705
S158	LA-49	S295	LA-206	A104	LA-90	A399	LA-64	B140	L-59
S161	LA-52B	S298	LA-209	A106	LA-66	A40	LA-59A	B141	L-38
S163-1	LA-41	S3	L-609	A108	LA-73	A41N	LA-605	B142	L-68
S164	LA-40A	S300	LA-211	A110	LA-83	A42	LA-607	B145	L-706A
S167	LA-44	S301	LA-212	A111	LA-79	A43	LA-608	B147	L-703
S170	LA-68	S302	LA-214	A112	LA-705	A465	LA-409G	B151	L-21A
S171-2	LA-79	S305	LA-302	A134	LA-314	A466	LA-414G	B154	L-268
S173	LA-50B	S306	LA-303	A140	LA-59	A477	LA-40B	B156	L-603A
S174	LA-55	S307	LA-304	A141	LA-38	A47N	LA-701	B192	L-52C
S175-1	LA-54	S308	LA-305	A142	LA-68	A48	LA-706	B194	L-50B
S183	LA-80	S310	LA-307	A145	LA-706A	A497	LA-53	B197	L-63
S186	LA-63	S311	LA-308	A147	LA-703	A50	LA-281	B227	L-41
S187	LA-59	S313	LA-310	A151	LA-21A	A52	LA-209	B234	L-707
S190	L-41	S315	LA-312	A154	LA-268	A54	LA-24	B246	L-76
S192-1	LA-40B	S316	LA-314	A155	LA-42	A55	LA-25	B248	L-706V
S194	LA-36G	S319	LA-404	A156	LA-603A	A56	LA-603	B253	L-214A
S2	L-603	S320	LA-406	A181	LA-27	A57	LA-23	B280	L-28A
S200	L-211	S322-1	LA-65	A192	LA-52C	A58	LA-71	B292	L-52B
S201	L-212	S325-1	LA-414G	A194	LA-50B	A59	LA-31	B32	L-86

NOTE: COMPETITIVE PART NUMBERS LISTED ARE INTERCHANGEABLE WITH OUR NUMBERS, BUT NOT NECESSARILY IDENTICAL.

SLEEVE INTERCHANGE CHART



VERSNICK TO L.A. SLEEVE SUGGESTED SLEEVE INTERCHANGE (cont'd)

VERSNICK	OUR NO.	VERSNICK	OUR NO.	VERSNICK	OUR NO.	VERSNICK	OUR NO.	VERSNICK	OUR NO.
B321	L-238F	B497	L-53	P118A	L-315	P238	L-506	P68	L-305
B333	L-20A	B50	L-281	P119	LA-308	P248	L-508	P69	LA-303
B336	L-002	B54	L-24	P128	L-400	P258	L-510	P8	L-215
B337	L-245	B55	L-25	P138	L-402	P268	L-512	P808A	L-211
B338	L-276	B56	L-603	P139	LA-310	P278	L-514	P809A	LA-211
B339	L-56	B57	L-23	P148	L-404	P28	L-301	P88	L-307
B34	L-609	B58	L-71	P148A	L-405	P288	L-600	P89	LA-305
B340	L-270	B60N	L-30	P149	LA-312	P29	LA-215	P8A	L-214
B341	L-281F	B62	L-704	P149A	LA-313	P298JD	L-711AP	P8AA	L-213
B348	L-298	B63	L-34	P158	L-406	P308	L-712AP	P8B	L-212
B35	L-606	B66N	L-602	P168	L-408	P328	L-713AP	P9	LA-212
B356N	L-603C	B70	L-304	P168A	L-409	P348JD	L-714AP	P90A	LA-201
B362	L-272	B78	L-44	P169	LA-400	P358	L-715AP	P98	L-308
B364	L-259	B81	L-27	P178	L-410	P378	L-716AP	P9A	LA-213
B366	L-255	B86	L-78	P178A	L-411	P38	L-302		
B377	L-49	B88	L-88	P179	LA-402	P388	L-717AP		
B38	L-87	B89	L-55	P179A	LA-403	P39	LA-300		
B39	L-862	B91	L-46	P18	L-300	P398	L-718AP		
B397	L-53A	B93	L-72	P188	L-412	P408	L-202		
B40	L-59A	B94	L-401	P189	LA-404	P408A	L-203		
B41N	L-605	B95	L-80	P19	LA-214	P409	LA-202		
B42	L-607	B96	L-54	P198	L-414	P409A	LA-203		
B43	L-608	P08A	L-201	P199	LA-406	P49	LA-301		
B44	L-608A	P108A	L-310	P208	L-500	P508A	L-205		
B465	L-409G	P108B	L-312	P209A	LA-409	P509A	LA-205		
B477	L-40B	P108C	L-313	P209C	LA-411	P59	LA-302		
B47N	L-701	P109	LA-307	P218	L-502	P608A	L-207		
B48	L-706	P118	L-314	P228	L-504	P609	LA-206		

NOTE: COMPETITIVE PART NUMBERS LISTED ARE INTERCHANGEABLE WITH OUR NUMBERS, BUT NOT NECESSARILY IDENTICAL.



ALL PURPOSE SLEEVES
Truck - Compressor - Forklift - for Engines
not listed in Cut to Length Sleeves

Sleeve Inside Diameter	3/32" Wall		1/8" Wall		5/32" Wall		Sleeve Length
	Part No.	O.D.	Part No.	O.D.	Part No.	O.D.	
1-3/8"	LA-106	1-9/16"	L-106	1-5/8"			4-1/2"
1-7/16"	LA-107	1-5/8"	L-107	1-11/16"			4-1/2"
1-1/2"	LA-108	1-11/16"	L-108	1-3/4"			4-1/2"
1-9/16"	LA-109	1-3/4"	L-109	1-13/16"			4-1/2"
1-5/8"	LA-110	1-13/16"	L-110	1-7/8"			6-1/2"
1-11/16"	LA-111	1-7/8"	L-111	1-15/16"			6-1/2"
1-3/4"	LA-112	1-15/16"	L-112	2"			6-1/2"
1-13/16"	LA-113	2"	L-113	2-1/16"			6-1/2"
1-7/8"	LA-114	2-1/16"	L-114	2-1/8"			6-1/2"
1-15/16"	LA-115	2-1/8"	L-115	2-3/16"			6-1/2"
2"	LA-200	2-3/16"	L-200	2-1/4"			6-1/4"
2-1/16"	LA-201	2-1/4"	L-201	2-5/16"			6-1/4"
2-1/8"	LA-202	2-5/16"	L-202	2-3/8"			6-1/4"
2-3/16"	LA-203	2-3/8"	L-203	2-7/16"			6-1/4"
2-1/4"	LA-204	2-7/16"	L-204	2-1/2"			6-1/4"
2-5/16"	LA-205	2-1/2"	L-205	2-9/16"			6-1/4"
2-3/8"	LA-206	2-9/16"	L-206	2-5/8"			6-1/4"
2-7/16"	LA-207	2-5/8"	L-207	2-11/16"			6-1/4"
2-1/2"	LA-208	2-11/16"	L-208	2-3/4"			6-1/4"
2-9/16"	LA-209	2-3/4"	L-209	2-13/16"			6-1/4"
2-5/8"	LA-210	2-13/16"	L-210	2-7/8"			6-1/4"
2-11/16"	LA-211	2-7/8"	L-211	2-15/16"			8-1/4"
2-3/4"	LA-212	2-15/16"	L-212	3"			8-1/4"
2-13/16"	LA-213	3"	L-213	3-1/16"			8-1/4"
2-7/8"	LA-214	3-1/16"	L-214	3-1/8"			8-1/4"
2-15/16"	LA-215	3-1/8"	L-215	3-3/16"			8-1/4"
3"	LA-300	3-3/16"	L-300	3-1/4"			8-1/4"
3-1/16"	LA-301	3-1/4"	L-301	3-5/16"			8-1/4"
3-1/8"	LA-302	3-5/16"	L-302	3-3/8"			9-1/4"
3-3/16"	LA-303	3-3/8"	L-303	3-7/16"			9-1/4"
3-1/4"	LA-304	3-7/16"	L-304	3-1/2"			9-1/4"
3-5/16"	LA-305	3-1/2"	L-305	3-9/16"			9-1/4"
3-3/8"	LA-306	3-9/16"	L-306	3-5/8"			9-1/4"
3-7/16"	LA-307	3-5/8"	L-307	3-11/16"			9-1/4"
3-7/16"	LA-307L	3-5/8"					10"
3-1/2"	LA-308	3-11/16"	L-308	3-3/4"			9-1/4"
3-9/16"	LA-309	3-3/4"	L-309	3-13/16"			9-1/4"
3-5/8"	LA-310	3-13/16"	L-310	3-7/8"	HD-310	3-15/16"	10-1/4"
3-11/16"	LA-311	3-7/8"	L-311	3-15/16"			10-1/4"
3-3/4"	LA-312	3-15/16"	L-312	4"	HD-312	4-1/16"	10-1/4"
3-13/16"	LA-313	4"	L-313	4-1/16"			10-1/4"
3-7/8"	LA-314	4-1/16"	L-314	4-1/8"	HD-314	4-3/16"	10-1/4"
3-15/16"	LA-315	4-1/8"	L-315	4-3/16"			10-1/4"

ALL PURPOSE SLEEVES
Truck - Compressor - Forklift - for Engines
not listed in Cut to Length Sleeves



Sleeve Inside Diameter	3/32" Wall		1/8" Wall		5/32" Wall		Sleeve Length
	Part No.	O.D.	Part No.	O.D.	Part No.	O.D.	
4"	LA-400	4-3/16"	L-400	4-1/4"	HD-400	4-5/16"	10-1/4"
4"	LA-400L	4-3/16"	L-400L	4-1/4"			10-3/4"
4-1/16"	LA-401	4-1/4"	L-401	4-5/16"			10-1/4"
4-1/8"	LA-402	4-5/16"	L-402	4-3/8"	HD-402	4-7/16"	10-1/4"
4-3/16"	LA-403	4-3/8"	L-403	4-7/16"			10-1/4"
4-1/4"	LA-404	4-7/16"	L-404	4-1/2"	HD-404	4-9/16"	10-1/4"
4-5/16"	LA-405	4-1/2"	L-405	4-9/16"			10-1/4"
4-3/8"	LA-406	4-9/16"	L-406	4-5/8"	HD-406	4-11/16"	10-1/4"
4-7/16"	LA-407	4-5/8"	L-407	4-11/16"			10-1/4"
4-1/2"	LA-408	4-11/16"	L-408	4-3/4"	HD-408	4-13/16"	10-1/4"
4-9/16"	LA-409	4-3/4"	L-409	4-13/16"			10-1/4"
4-5/8"	LA-410	4-13/16"	L-410	4-7/8"	HD-410	4-15/16"	12-1/4"
4-11/16"	LA-411	4-7/8"	L-411	4-15/16"			12-1/4"
4-3/4"	LA-412	4-15/16"	L-412	5"	HD-412	5-1/16"	12-1/4"
4-7/8"	LA-414	5-1/16"	L-414	5-1/8"	HD-414	5-3/16"	12-1/4"
5"	LA-500	5-3/16"	L-500	5-1/4"	HD-500	5-5/16"	12-1/4"
5-1/8"	LA-502	5-5/16"	L-502	5-3/8"	HD-502	5-7/16"	12-1/4"
5-1/4"	LA-504	5-7/16"	L-504	5-1/2"	HD-504	5-9/16"	12-1/4"
5-3/8"	LA-506	5-9/16"	L-506	5-5/8"			12-1/4"
5-1/2"	LA-508	5-11/16"	L-508	5-3/4"	HD-508	5-13/16"	12-1/4"
5-5/8"	LA-510	5-13/16"	L-510	5-7/8"	HD-510	5-15/16"	12-1/4"
5-3/4"	LA-512	5-15/16"	L-512	6"	HD-512	6-1/16"	12-1/4"
5-7/8"	LA-514	6-1/16"	L-514	6-1/8"	HD-514	6-3/16"	12-1/4"
6"	LA-600	6-3/16"	L-600	6-1/4"	HD-600	6-5/16"	12-1/4"
6-1/8"	LA-711AP	6-5/16"	L-711AP	6-3/8"	HD-711AP	6-7/16"	12-1/8"
6-1/4"	LA-712AP	6-7/16"	L-712AP	6-1/2"	HD-712AP	6-9/16"	12-1/8"
6-1/2"	LA-713AP	6-11/16"	L-713AP	6-3/4"	HD-713AP	6-13/16"	12-1/8"
6-3/4"	LA-714AP	6-15/16"	L-714AP	7"	HD-714AP	7-1/16"	13"
7"	LA-715AP	7-3/16"	L-715AP	7-1/4"	HD-715AP	7-5/16"	13"
7-1/2"	LA-716AP	7-11/16"	L-716AP	7-3/4"			13"
7-3/4"	LA-717AP	7-15/16"	L-717AP	8"			13"
7-7/8"	LA-719AP	8-1/16"	L-719AP	8-1/8"			11-5/16"
8"	LA-718AP	8-3/16"	L-718AP	8-1/4"			13"
8-1/8"	LA-720AP	8-5/16"	L-720AP	8-3/8"			13"
8-1/4"	LA-721AP	8-7/16"	L-721AP	8-1/2"			13"

CUT TO LENGTH SLEEVES TRUCK - TRACTOR - FORKLIFT



Engine Model	Application	Size	Part No.
--------------	-------------	------	----------

ALLIS CHALMERS TRACTOR

Tractor	5-1/4" Flanged Replacement Sleeve		FL-3713
---------	-----------------------------------	--	---------

CASE REPAIR RING

ALL REPAIR RINGS ARE SOLD IN PACKAGES OF 6

207	Upper repair ring blank	4.190" x 4.625" x .500"	NW4625-6
	Lower repair ring	4.225" x 4.400" x 1"	NW4400-6
	Lower repair ring	4.225" x 4.420" x 1"	NW4420-6
336	Upper repair ring blank	5.100" x 5.560" x .525"	CR5560-6
	Lower repair ring semi bore	5.000" x 5.187" x 1.200"	LAS5187-6
401	Upper repair ring blank	4.812" x 5.175" x .625"	CR5175-6
	Lower repair ring semi bore	4.620" x 4.815" x 1.200"	LAS4815-6
451	Upper repair ring blank	4.900" x 5.420" x .500"	LAS5420-6
	Lower repair ring	4.120" x 4.315" x 1.200"	LAS4315-6
504	Upper repair ring blank	5.100" x 5.560" x .525"	CR5560-6
	Lower repair ring semi bore	5.000" x 5.187" x 1.200"	LAS5187-6

Engine Model	Cyl. Bore	1/16" Wall		3/32" Wall		1/8" Wall		Sleeve Length
		Part No.	O.D.	Part No.	O.D.	Part No.	O.D.	

CATERPILLAR

3208, 3204	4-1/2"			LA-64	4-11/16"	L-64	4-3/4"	7-3/4"
3208, 3204	4-1/2"			LA-640	4-11/16"	L-640	4-3/4"	8"
3208, 3204	4-1/2"					L-642	4.774"	8"
3208, 3204	4-1/2"					L-645	4.804"	7-7/8"
3208, 3204	4-1/2"				3/16" Wall	L-650	4.875"	8"
3208, 3204	4-1/2"				1/4" Wall	L-660	5"	8"
3116	4.134"	Not recommended for Cracked Blocks		LA-671	4.323"	L-671	4.386"	7-3/4"
3116	4.134"	Flange Sleeve		LA-671FL	4.335"	Recommended for Cracked Blocks		7-7/8"
3126	4.330"	Not recommended for Cracked Blocks		LA-672	4.523"	L-672	4.585"	7-3/4"
3126	4.330"	Flange Sleeve		LA-672FL	4.530"	Recommended for Cracked Blocks		7-7/8"
C12, 11.9L Diesel 1996-03	130mm	Flanged Replacement	Sleeve Part No. FL-3214					

Engine Model	Application	Size	Part No.
--------------	-------------	------	----------

CATERPILLAR THREAD REPAIR BUSHING

3406, 3408, 3412	Thread Insert Bushing		LAS8704
3400	Thread Insert Bushing	2-3/4" OAL	LAS8703

CATERPILLAR REPAIR RINGS

ALL REPAIR RINGS ARE SOLD IN PACKAGES OF 6

Caterpillar 3300	Upper repair ring blank spacer plate block	5.450" x 5.800" x .205"	CR5801-6
	Upper repair ring blank	5.450" x 5.800" x .653"	LAS5450-6
Caterpillar 3306	Upper repair ring blank	5.474" x 5.800" x .700"	NW5802-6
	Upper repair ring blank +.020	5.474" x 5.820" x .700"	NW5820S-6
	Upper repair ring blank +.020	5.474" x 5.820" x .720"	NW5821-6
	Upper repair ring blank		LAS8220-6
	Lower repair ring	5.200" x 5.442" x 1.375"	CR5442-6
	Lower repair ring +.020	5.200" x 5.462" x 1.375"	CR5462-6
	Lower repair ring +.065	5.235" x 5.505" x 1.250"	CR6505-6
	Spacer plate	5.472" x 5.820" x .360"	LAS5472-6
Caterpillar 3400	Upper repair ring	6.200" x 6.600" x .312"	NW6600-6
	Upper repair ring	6.230" x 6.665" x .205"	CR6665-6
	Upper repair ring	6.230" x 6.665" x .250"	CR6665L-6
	Upper repair ring	6.250" x 6.665" x .205"	CR6665F-6
	Upper repair ring	x 6.642" x .355"	CR6642-6
	Lower repair ring	6.020" x 6.255" x 1.625"	CR6253-6
Caterpillar 3406	Upper repair ring finish bore	6.259" x 6.632" x .350"	CR6640-6
	Upper repair ring finish bore +.010	6.259" x 6.642" x .350"	CR6641-6
	Upper repair ring finish bore +.020	6.259" x 6.652" x .350"	CR6642-6
	Upper repair ring finish bore +.050	6.259" x 6.682" x .350"	CR6645-6

Engine Model	Application	Size	Part No.
--------------	-------------	------	----------

CATERPILLAR REPAIR RINGS (Cont.)

Caterpillar V3412 Caterpillar 3400	Lower repair ring	6" x 6.220" O.D. x 1.300"	CR6220-6
	Lower repair ring +.010	6" x 6.230" O.D. x 1.300"	CR6230-6
	Lower repair ring +.020	6" x 6.240" O.D. x 1.300"	CR6240-6
	Lower repair ring Finish Bore	6.058" x 6.220" x 1.300"	CR6220F-6
	Lower repair ring Finish Bore +.010	6.058" x 6.230" x 1.300"	CR6230F-6
	Lower repair ring Finish Bore +.020	6.058" x 6.240" x 1.300"	CR6240F-6
Caterpillar 3500	Lower repair ring	7.600" x 7.789" x 1.420"	LAS7789-6
	Semi finish upper repair ring	7.800" x 8.358" x .302"	LAS8358-6
Caterpillar 343, Caterpillar 1693	Upper repair ring		LAS8230-6
	Upper repair ring +.010		LAS8231-6
	Upper repair ring +.020		LAS8232-6
	Lower repair ring	6.080" x 6.255" x 1.625"	CR6254-6
	Lower repair ring	6.020" x 6.255" x 1.315"	CR6256-6
Caterpillar D-8	Upper repair ring blank	6.660" x 7.200" x .725"	NW7200-6
	Upper repair ring + .100	6.660" x 7.300" x .800"	NW7300-6
	Flanged upper repair ring blank	6.720" x 7.478" flange x .800"	FL7478-6
	Flanged upper blank oversize O.D.	6.720" x 7.775" x 1"	FL7775-6
Caterpillar D-9	Upper repair ring blank	7.170" x 7.750" x .700"	NW7750-6
	Upper repair ring + .100	7.170" x 7.850" x .800"	NW7850-6
	Flanged upper repair ring blank	7.220" x 7.995" flange x .800"	FL7995-6
	Flanged upper blank oversize O.D.	7.720" x 8.320" flange x .920"	FL8320-6
	Lower repair ring	7.070" x 7.240" x 1.750"	NW7240-6
Caterpillar D-9 H	Upper repair ring blank	7.170" x 7.750" x .312"	NW7750S-6

Engine Model	Year	Cyl. Bore	1/16" Wall		3/32" Wall		1/8" Wall		Sleeve Length
			Part No.	O.D.	Part No.	O.D.	Part No.	O.D.	

CONTINENTAL

N-62		2-3/8"	T-206A	2-1/2"	LA-206A	2-9/16"	L-206A	2-5/8"	6"
Y-69		2-1/2"	T-208A	2-5/8"	LA-208A	2-11/16"	L-208A	2-3/4"	6"
Y-91		2-7/8"	T-214A	3"	LA-214A	3-1/16"	L-214A	3-1/8"	6"
T-112		3-3/16"	T-603A	3-5/16"	LA-603A	3-3/8"	L-603A	3-7/16"	6"
F-199		3-1/4"	T-605	3-3/8"	LA-605	3-7/16"	L-605	3-1/2"	8-1/8"
F-4124, F-6186		3"	T-30	3-1/8"	LA-30	3-3/16"	L-30	3-1/4"	7-1/2"
F-4140		3-3/16"	T-33	3-5/16"	LA-33	3-3/8"	L-33	3-7/16"	7-1/2"
F-4162, F-163, F-245		3-7/16"	T-703	3-9/16"	LA-703	3-5/8"	L-703	3-11/16"	7-1/2"
D-6170		3-1/2"	T-710	3-5/8"	LA-710	3-11/16"	L-710	3-3/4"	8-1/4"
F-6209		3-3/16"	T-33	3-5/16"	LA-33	3-3/8"	L-33	3-7/16"	7-1/2"
F-6226, F-227		3-5/16"	T-607	3-7/16"	LA-607	3-1/2"	L-607	3-9/16"	7-9/16"
K-6271		3-5/8"	T-23C	3-3/4"	LA-23C	3-13/16"	L-23C	3-7/8"	8"
K-6290		3-3/4"			LA-75	3-15/16"	L-75	4"	7-1/2"
K-6330		4"			LA-400	4-3/16"	L-400	4-1/4"	10-1/4"
TM-13, TMD-13		3.582"	T-005	3.712"	LA-005	3.769"	L-005	3.832"	6-1/4"
TM-20, TMD-20		3.582"	T-005	3.712"	LA-005	3.769"	L-005	3.832"	6-1/4"
TMD-27, TMD-40		3.582"	T-005	3.712"	LA-005	3.769"	L-005	3.832"	6-1/4"

CONTINENTAL FLANGE TYPE SLEEVES

Z-129		3-3/8"	Replacement Sleeve FL-3181	6.940"
F20		3-3/4"	Replacement Sleeve FL-3152	9.082"
GB176		3.658"	Replacement Sleeve FL-3182	7-5/8"
ED208 Diesel	1955-63	3-11/16"	Replacement Sleeve FL-3201	8.550"
G193		3-3/4"	Replacement Sleeve FL-3119*	7-5/8"
G206		3-13/16"	Replacement Sleeve FL-3154	7-5/8"
E201		3-5/8"	Replacement Sleeve FL-3120	8-9/16"
E223		3-13/16"	Replacement Sleeve FL-3121	8-9/16"
E242		3-7/8"	Replacement Sleeve FL-3155	8-9/16"
JD403		4-5/8"	Replacement Sleeve FL-3122	11.468"
JD, J382A		4-1/2"	Replacement Sleeve FL-3174	11.468"

Available Oversize O.D. +.010, +.020, +.030 Allow 4 weeks for delivery.

CUT TO LENGTH SLEEVES TRUCK - TRACTOR - FORKLIFT

L.A. SLEEVE

Engine Model	Application	Size	Part No.
--------------	-------------	------	----------

CUMMINS REPAIR RING, CAM BUSHING, THREAD INSERTS

ALL REPAIR RINGS ARE SOLD IN PACKAGES OF 6

250, 335, 350	Upper finished counterbore	6.315" x 6.754" x .602"	LAS8000-6
855, 5-1/2 NH, NTC	Upper finished counterbore O.D. +.010 / +.010 OAL.	6.315" x 6.764" x .612"	LAS8010-6
Inline 6 cyl.,	Upper finished counterbore O.D. +.020 / +.020 OAL.	6.315" x 6.774" x .622"	LAS8020-6
V-12	Upper finished counterbore O.D. +.030 / +.030 OAL.	6.315" x 6.784" x .632"	LAS8030-6
5-1/2" Bore Motors	Lower press fit finished counterbore	6.299" x 6.754" x .751"	LAS9040LPF-6
	Lower press fit finished counterbore O.D. +.010 / +.010 OAL.	6.299" x 6.764" x .761"	LAS9041LPF-6
	Lower press fit finished counterbore O.D. +.020 / +.020 OAL.	6.299" x 6.774" x .771"	LAS9042LPF-6
	Lower press fit finished counterbore O.D. +.030 / +.030 OAL.	6.299" x 6.784" x .781"	LAS9043LPF-6
	Upper repair ring blank	6.275" x 6.754" x .675"	NW6750-6
	Upper repair ring blank +.020	6.275" x 6.774" x .675"	NW6770-6
	Upper repair ring blank +.030	6.275" x 6.784" x .675"	NW6780-6
	Lower repair ring finished bore	6.125" x 6.255" x 1.750"	LAS6255F-6
	Lower repair ring finished bore +.010	6.125" x 6.265" x 1.750"	LAS6265F-6
	Lower repair ring finished bore +.020	6.125" x 6.275" x 1.750"	LAS6275F-6
	Lower repair ring semi-bore	6.070" x 6.250" x 1.750"	NW6250-6
	Lower repair ring semi-bore +.005	6.070" x 6.255" x 1.750"	CR6255-6
	Lower repair ring semi-bore +.015	6.070" x 6.265" x 1.750"	CR6265-6
	Lower repair ring semi-bore +.020	6.070" x 6.270" x 1.750"	NW6270-6
	Lower repair ring semi-bore +.030	6.070" x 6.280" x 1.750"	NW6280-6
5-1/2 NH Big Cam	Cam Repair Bushing (#3 or #5 journal)	2.690" x 2.813" x 2.192"	LAS8627-6
	Cam Repair Bushing (#3 or #5 journal) +.020 O.D.	2.690" x 2.835" x 2.192"	LAS86272-6
	Cam Repair Bushing (#1, #2, #4, #6 or #7 journal)	2.690" x 2.813" x 1.690"	LAS8614-6
	Cam Repair Bushing (#1, #2, #4, #6 or #7 journal) +.020 O.D.	2.690" x 2.835" x 1.690"	LAS86142-6
5-1/8 NH, 5-1/2 NH	Cam Repair Bushing (intermediate)	2.132" x 2.252" x 1.687"	LAS8603-6
	Cam Repair Bushing (intermediate) +.020 O.D.	2.132" x 2.272" x 1.687"	LAS86032-6
	Cam Repair Bushing (front)	2.132" x 2.252" x 2.253"	LAS8604-6
	Cam Repair Bushing (front) +.020 O.D.	2.132" x 2.272" x 2.253"	LAS86042-6
5-1/2 NH, V12, 903	Thread Insert Bushing	2-2/32" OAL	LAS-8700
		3-3/32" OAL	LAS-8705
L10	Thread Insert Bushing	2" OAL	LAS-8710
C Series	Thread Insert Bushing	2" OAL	LAS-8715
903	Upper repair ring blank	6.170" x 6.625" x .675"	CR6625-6
	Upper repair ring +.020	6.170" x 6.645" x .675"	CR6645-6
V903	Lower repair ring	6.020" x 6.300" x 1.750"	CR6300-6
	Lower repair ring	6.020" x 6.300" x 1.250"	CR6302-6

Engine Model	Year	Cyl. Bore	1/16" Wall		3/32" Wall		1/8" Wall		Sleeve Length
			Part No.	O.D.	Part No.	O.D.	Part No.	O.D.	
L-643TA		3.500"	T-708H	3-5/8"					6-5/8"
3.9L 4 cyl.		4.016"	T-670	4.118"	LA-670	4.180"	L-670	4.270"	7-7/8"

Engine Model	Year	Cyl. Bore	1/16" Wall		3/32" Wall		1/8" Wall		Sleeve Length
			Part No.	O.D.	Part No.	O.D.	Part No.	O.D.	

DETROIT DIESEL

ALL REPAIR RINGS ARE SOLD IN PACKAGES OF 6

8.2		4-1/4"			LA-63B	4-7/16"	L-63B	4-1/2"	7.760"
6-71, 8-71		4-1/4"			FL-155F*	REPLACEMENT SLEEVE			
71 Series upper ring		4-5/8"			FL01555A-6	4.830"	Flanged Sleeve		3-1/2"
8V71 Series upper ring		4-5/8"			RBU58NW-6	4.830"	Flanged Sleeve		3-3/4"
71 Series upper ring	NEW	4-5/8"			LA410DD-6	4-13/16"			3-1/2"
71 Series upper ring	OLD	4-5/8"			LA410DR-6	4-13/16"			4"
671 Series upper ring		4-5/8"			LA410DL-6	4-13/16"			5-3/4"
92 Series lower repair ring		5.090"			CR5320-6	5.320"			3.625"
60 Series upper ring finish bore		5.875"			LAS8065-6	6.375"			.602"
60 Series upper ring finish bore +.010		5.875"			LAS8075-6	6.385"			.602"
60 Series upper ring finish bore +.020		5.875"			LAS8085-6	6.395"			.602"
60 Series upper ring finish bore +.030		5.875"			LAS8095-6	6.405"			.602"
60 Series lower ring semi bore		5.730"			LAS8066-6	5.935"			1.062"
60 Series lower ring semi bore +.010		5.730"			LAS8076-6	5.945"			1.062"
60 Series lower ring semi bore +.020		5.730"			LAS8086-6	5.9055"			1.062"
60 Series lower ring finish bore		5.758"			LAS8066F-6	5.935"			1.062"
60 Series lower ring finish bore +.020		5.758"			LAS8086F-6	5.955"			1.062"

FORD TRACTOR

99A-6055		3-3/16"	FL-118	3.271"	Flanged Sleeve				
8N-6005-B		3-3/16"			FL-120	3.3695"	Flanged Sleeve		7.000"
Tractor 3 cyl		4.200"	T-7120	4.325"	LA-7120	4.388"			8.000"
Ford Lehman 6 cyl		4.220"	T-7110	4.345"	LA-7110	4.408"	L-7110	4.470"	8.000"
D7NN-6005-A		4.400"	FL-121	4.505"	Flanged Sleeve				8.200"
6.6 L		4.400"	T-406A	4.505"	LA-406A	4-9/16"	L-406A	4-5/8"	7.875"
7.8 L		4.400"	T-406B	4.505"	LA-406B	4-9/16"	L-406B	4-5/8"	8-3/4"

Engine Model	Application	Size	Part No.
--------------	-------------	------	----------

DETROIT DIESEL THREAD REPAIR BUSHINGS

60 Series	Thread Repair Bushing	2-9/16" OAL"	LAS-8707
71 Series	Thread Repair Bushing	2-7/16" OAL"	LAS-8708
92 Series 8V92 6, 8, 12, 16 Cylinder	Thread Repair Bushing	2.210" OAL"	LAS-8709

CUT TO LENGTH SLEEVES TRUCK - TRACTOR - FORKLIFT



Engine Model	Year	Cyl. Bore	1/16" Wall		3/32" Wall		1/8" Wall		Sleeve Length	
			Part No.	O.D.	Part No.	O.D.	Part No.	O.D.		
DODGE TRUCKS										
105, 1.7 L	1978-83	3.130"	T-706A	3-1/4"	LA-706A	3-5/16"	L-706A	3-3/8"	6-7/8"	
122, 2.0 L	1974-82	3.307"	T-281	3-7/16"	LA-281	3-1/2"	L-281	3-9/16"	6-1/2"	
135, 2.2 L	1981-95	3.445"			LA-38	3-5/8"	L-38	3-11/16"	6"	
143, 2.4 L	1986-96	3.406"	T-59	3.525"	LA-59	3.587"	L-59	3.650"	7"	
153, 2.5 L	1986-95	3.425"	T-38	3-9/16"	LA-38	3-5/8"	L-38	3-11/16"	6"	
156, 2.6 L	1978-89	3.582"	T-005	3.712"	LA-005	3.769"	L-005	3.832"	6.25"	
170	1960-71	3.400"	T-59A	3.525"	LA-59A	3.587"	L-59A	3.650"	6"	
181, 3.0 L	1986-00	3.582"	T-005	3.712"	LA-005	3.769"	L-005	3.832"	6-1/4"	
198	1970-74	3.400"	T-59	3.525"	LA-59	3.587"	L-59	3.650"	7"	
201, 3.3 L	1990-00	3.661"	T-353	3.786"	LA-353	3.848"	L-353	3.911"	6-1/2"	
218	1934-54	3-1/4"	T-605	3-3/8"	LA-605	3-7/16"	L-605	3-1/2"	8-1/8"	
225, 3.7 L	1960-87	3.400"	T-59	3.525"	LA-59	3.587"	L-59	3.650"	7"	
230	1946-60	3-1/4"			LA-605	3-7/16"	L-605	3-1/2"	8-1/8"	
236	1949-53	3-7/16"			LA-701	3-5/8"	L-701	3-11/16"	8-1/8"	
237	1942-51	3-7/16"			LA-701	3-5/8"	L-701	3-11/16"	8-1/8"	
238, 3.9 L	1986-00	3.910"			LA-55	4.097"	L-55	4.160"	6-1/16"	
251	1949-68	3-7/16"			LA-701	3-5/8"	L-701	3-11/16"	8-1/8"	
259	1942-69	3-7/16"			LA-701	3-5/8"	L-701	3-11/16"	8-1/8"	
273	1964-69	3-5/8"			LA-24	3-13/16"	L-24	3-7/8"	6"	
318, 5.2 L	1957-00	3.910"			LA-55	4.097"	L-55	4.160"	6-1/16"	
359, 5.9 L	1998-00	4.016"	T-40B	4-1/8"	LA-40B	4-3/16"	L-40B	4-1/4"	6-1/2"	
361	1958-66	4-1/8"			LA-51	4-5/16"	L-51	4-3/8"	6-5/16"	
383	1959-71	4-1/4"			LA-53	4-7/16"	L-53	4-1/2"	6-5/8"	
400, 6.6 L	1972-78	4.342"			LA-83	4.530"	L-83	4.592"	6-1/4"	
413	1959-77	4-3/16"			LA-57	4-3/8"	L-57	4-7/16"	7"	
440, 7.2 L	1966-81	4.320"			LA-65	4-1/2"	L-65	4-9/16"	6-3/4"	
446	1979-81	4-1/8"			LA-52	4-5/16"	L-52	4-3/8"	7-1/4"	
478	1969-77	4-1/2"			LA-64	4-11/16"	L-64	4-3/4"	7-3/4"	
FORD TRUCKS										
85 HP Flathead		3-1/16"	Flanged Replacement Sleeve				FL-3204	3.145"	6.480"	
110, 1.8 L	1972-78	3.071"	T-602	3-1/16"	LA-602	3-1/4"	L-602	3-5/16"	6-1/2"	
116, 1.9 L	1977-97	3.228"			LA-002	3.415"	L-002	3.478"	6"	
121, 2.0 L	1979-82	3.150"	T-298	3.275"	LA-298	3.337"	L-298	3.399"	5-15/16"	
122, 2.0 L	1983-88	3.516"	T-296	2.644"	LA-296	2.706"	L-296	2.769"	6-1/2"	
2.2 L Diesel (Mazda Diesel)	1983	89mm	Flanged Replacement Sleeve				FL-3205	3.815"	6.585"	
140, 2.3 L	1977-97	3.780"			LA-28A	3.968"	L-28A	4-1/32"	6"	

Engine Model	Year	Cyl. Bore	1/16" Wall		3/32" Wall		1/8" Wall		Sleeve Length
			Part No.	O.D.	Part No.	O.D.	Part No.	O.D.	
FORD TRUCKS (Cont.)									
144	1960-64	3-1/2"	T-20A	3-5/8"	LA-20A	3-11/16"	L-20A	3-3/4"	5-5/16"
152, 2.5 L	1998-00	3.781"			LA-28	3.968"	L-28	4.031"	7-3/4"
170	1961-72	3-1/2"	T-20A	3-5/8"	LA-20A	3-11/16"	L-20A	3-3/4"	5-5/16"
171, 2.8 L	1974-92	3.660"			LA-85	3.847"	L-85	3.910"	6-1/2"
172, 192		3.900"			LA-90	3.087"	L-90	4.150"	7"
172, 192		3.900"			FL-3161	4.100"	Flanged Sleeve		6.915"
172, 192		3.900"			FL-3162	4.120"	Flanged Sleeve		6.920"
177, 2.9 L	1986-92	3.661"	T-353	3.786"	LA-353	3.848"	L-353	3.911"	6-1/2"
182, 3.0 L	1986-05	3-1/2"	T-20	3-5/8"	LA-20	3-11/16"	L-20	3-3/4"	6"
181, 3.0 L	1993-95	3-7/16"			LA-38	3-5/8"	L-38	3-11/16"	6"
200	1965-74	3.680"	T-37A	3-13/16"	LA-37A	3-7/8"	L-37A	3-15/16"	5-1/8"
215	1952-53	3.567"	T-608A	3-11/16"	LA-608A	3-3/4"	L-608A	3-13/16"	7-1/4"
223	1954-64	3-5/8"	T-23	3-3/4"	LA-23	3-13/16"	L-23	3-7/8"	6-11/16"
226	1948-51	3.300"			LA-606	3.487"	L-606	3.550"	8-1/4"
232, 3.8 L	1982-00	3-13/16"			LA-43	4"	L-43	4-1/16"	6-5/8"
239	1944-53	3-3/16"	T-603	3-5/16"	LA-603	3-3/8"	L-603	3-7/16"	6-1/2"
239	1954-55	3-1/2"	T-20	3-5/8"	LA-20	3-11/16"	L-20	3-3/4"	6"
240	1965-74	4"			LA-41	4-3/16"	L-41	4-1/4"	6-5/8"
244, 4.0 L	1990-05	3.950"			LA-006	4.137"	L-006	4.200"	6-7/8"
255, 4.1 L	1980-82	3.680"			LA-37	3-7/8"	L-37	3-15/16"	6-5/8"
256	1954-55	3-5/8"	T-23	3-3/4"	LA-23	3-13/16"	L-23	3-7/8"	6-11/16"
256, 4.2 L	1997-05	3-13/16"			LA-42	4"	L-42	4-1/16"	6-7/8"
262	1961-64	3.720"			LA-27	3-29/32"	L-27	3-31/32"	7-3/4"
272	1955-58	3-5/8"			LA-24	3-13/16"	L-24	3-7/8"	6"
279	1952-55	3.567"	T-608A	3-11/16"	LA-608A	3-3/4"	L-608A	3-13/16"	7-1/4"
281, 4.6 L	1997-05	3.551"	T-21A	3-11/16"	LA-21A	3-3/4"	L-21A	3-13/16"	6"
289	1966-68	4"			LA-40B	4-3/16"	L-40B	4-1/4"	5-1/8"
292	1958-64	3-3/4"			LA-39B	3-15/16"	L-39B	4"	6-1/8"
300, 4.9 L	1965-96	4"			LA-49	4-3/16"	L-49	4-1/4"	6-7/8"
302	1956-63	3-5/8"	T-23C	3-3/4"	LA-23C	3-13/16"	L-23C	3-7/8"	8"
302, 5.0 L	1968-00	4"			LA-40B	4-3/16"	L-40B	4-1/4"	5-1/8"
317	1952-54	3.800"			LA-25	3.987"	L-25	4.050"	6-7/8"
330	1964-78	3-7/8"			LA-69	4-1/16"	L-69	4-1/8"	6-3/8"
330, 5.4 L	1997-05	3.552"			LA-372	3.740"	L-372	3.802"	6-1/2"
332	1956-63	3.800"			LA-25	3.987"	L-25	4.050"	6-7/8"
351, 5.8 L	1969-97	4"			LA-40A	4-3/16"	L-40A	4-1/4"	6-1/4"
352	1965-67	4"			LA-40A	4-3/16"	L-40A	4-1/4"	6-1/4"

CUT TO LENGTH SLEEVES TRUCK - TRACTOR - FORKLIFT



Engine Model	Year	Cyl. Bore	1/16" Wall		3/32" Wall		1/8" Wall		Sleeve Length
			Part No.	O.D.	Part No.	O.D.	Part No.	O.D.	
FORD TRUCKS (Cont.)									
359	1974-78	4.050"			LA-60	4-15/64"	L-60	4-19/64"	6-3/8"
360	1968-76	4.050"			LA-60	4-15/64"	L-60	4-19/64"	6-3/8"
361, 5.9 L	1964-78	4.050"			LA-60	4-15/64"	L-60	4-19/64"	6-3/8"
370, 6.1 L	1979-92	4.050"			LA-60	4-15/64"	L-60	4-19/64"	6-3/8"
389	1975-78	4.050"			LA-60	4-15/64"	L-60	4-19/64"	6-3/8"
390	1968-76	4.050"			LA-60	4-15/64"	L-60	4-19/64"	6-3/8"
391, 6.4 L	1964-78	4.050"			LA-60	4-15/64"	L-60	4-19/64"	6-3/8"
400, 6.6 L	1978-82	4"			LA-40A	4-3/16"	L-40A	4-1/4"	6-1/4"
401	1958-76	4-1/8"			LA-52C	4-5/16"	L-52C	4-3/8"	7-1/2"
415, 6.8 L	1997-05	3.551"			LA-372	3.740"	L-372	3.802"	6-1/2"
420, 6.9 L		4"			LA-49	4-3/16"	L-49	4-1/4"	6-7/8"
429, 7.0 L	1979-97	4-23/64"			LA-73	4-35/64"	L-73	4-39/64"	6-7/8"
445, 7.3 L	1988-00	4.110"			LA-007	4.297"	L-007	4.360"	8-3/4"
460, 7.5 L	1972-97	4.360"			LA-73	4-35/64"	L-73	4-39/64"	6-7/8"
475	1973-78	4-1/2"			LA-640	4-11/16"	L-640	4-3/4"	8"
477, 7.8 L	1958-81	4-1/2"			LA-640	4-11/16"	L-640	4-3/4"	8"
534, 8.7 L	1958-81	4-1/2"			LA-640	4-11/16"	L-640	4-3/4"	8"
6.6 Litre	1987-93	4.400"	T-406A	4.505"	LA-406A	4-9/16"			7.875"
476	1986-93	4.400"	T-406B	4.505"	LA-406B	4-9/16"			8-3/4"
G.M.C. TRUCKS									
97, 1.6 L	1992-95	2.952"	T-276	3.077"	LA-276	3.140"	L-276	3.202"	6-3/8"
98, 1.6 L	1998-00	2.952"	T-276	3.077"	LA-276	3.140"	L-276	3.202"	6-3/8"
110, 1.8 L	1972-82	3.307"	T-281F	3-7/16"	LA-281F	3-1/2"	L-281F	3-9/16"	5-5/8"
119, 1.9 L	1982-85	3.445"	T-38	3-9/16"	LA-38	3-5/8"	L-38	3-11/16"	6"
121, 2.0 L	1983-85	3-1/2"	T-708A	3-5/8"	LA-708A	3-11/16"	L-708A	3-3/4"	5-1/2"
133, 2.2 L	1994-96	3-1/2"	T-708A	3-5/8"	LA-708A	3-11/16"	L-708A	3-3/4"	5-1/2"
134, 2.2 L	1998-00	3-1/2"	T-708A	3-5/8"	LA-708A	3-11/16"	L-708A	3-3/4"	5-1/2"
151, 2.5 L	1985-93	4"			LA-40	4-3/16"	L-40	4-1/4"	6"
153	1963-66	3-7/8"			LA-68	4-1/16"	L-68	4-1/8"	6"
173, 2.8 L	1982-93	3-1/2"	T-20A	3-5/8"	LA-20A	3-11/16"	L-20A	3-3/4"	5-5/16"
181		4"			LA-40A	4-3/16"	L-40A	4-1/4"	6-1/4"
191, 3.1 L	1989-95	3-1/2"	T-20A	3-5/8"	LA-20A	3-11/16"	L-20A	3-3/4"	5-5/16"
194	1941-66	3-9/16"			LA-26	3-3/4"	L-26	3-13/16"	7-3/4"
200, 3.3 L	1978-79	3-1/2"	T-20A	3-5/8"	LA-20A	3-11/16"	L-20A	3-3/4"	5-5/16"
207, 3.4 L	1996-05	3-5/8"	T-24	3-3/4"	LA-24	3-13/16"	L-24	3-7/8"	6"
216	1941-53	3-1/2"	T-608	3-5/8"	LA-608	3-11/16"	L-608	3-3/4"	7-1/8"
230	1963-69	3-7/8"			LA-68	4-1/16"	L-68	4-1/8"	6"

Engine Model	Year	Cyl. Bore	1/16" Wall		3/32" Wall		1/8" Wall		Sleeve Length
			Part No.	O.D.	Part No.	O.D.	Part No.	O.D.	
G. M. C. TRUCKS (Cont.)									
231, 3.8 L	1992-05	3.800"			LA-25A	3.987"	L-25A	4.050"	6-1/8"
235, 3.8 L	1941-62	3-9/16"			LA-704	3-3/4"	L-704	3-13/16"	7-1/2"
248	1941-55	3-23/32"			LA-27	3-29/32"	L-27	3-31/32"	7-3/4"
250, 4.1 L	1966-84	3-7/8"			LA-69	4-1/16"	L-69	4-1/8"	6-3/8"
261	1954-62	3-3/4"			LA-44	3-15/16"	L-44	4"	7-1/4"
262, 4.3 L	1985-05	4"			LA-40	4-3/16"	L-40	4-1/4"	6"
265	1955-57	3-3/4"			LA-39A	3-15/16"	L-39A	4"	6"
267, 4.4 L	1979-82	3-1/2"			LA-708	3-11/16"	L-708	3-3/4"	6-3/4"
270	1952-63	3-25/32"			LA-28	3.968"	L-28	4-1/32"	7-3/4"
283	1957-67	3-7/8"			LA-68	4-1/16"	L-68	4-1/8"	6"
288	1955	3-3/4"			LA-75	3-15/16"	L-75	4"	7-1/2"
292, 4.8 L	1963-89	3-7/8"			LA-702	4-1/16"	L-702	4-1/8"	7-1/8"
302	1952-59	4"			LA-48	4-3/16"	L-48	4-1/4"	7-7/8"
305, 5.0 L	1960-90	4-1/4"			LA-63	4-7/16"	L-63	4-1/2"	7-5/8"
305, 5.0 L	1977-00	3.736"			LA-87	3-59/64"	L-87	3-63/64"	6-3/8"
307	1968-73	3-7/8"			LA-68	4-1/16"	L-68	4-1/8"	6"
316	1956	3-15/16"			LA-47	4-1/8"	L-47	4-3/16"	6-1/4"
318	1952-53	3-7/8"			LA-314	4-1/16"	L-314	4-1/8"	10-1/4"
324	1955-56	3-7/8"			LA-69	4-1/16"	L-69	4-1/8"	6-3/8"
327	1962-68	4"			LA-40	4-3/16"	L-40	4-1/4"	6"
336	1959	3.781"			LA-28	3.968"	L-28	4-1/32"	7-3/4"
348	1958-61	4-1/8"			LA-51	4-5/16"	L-51	4-3/8"	6-5/16"
350, 5.7 L	1967-00	4"			LA-40	4-3/16"	L-40	4-1/4"	6"
350, 5.7 L	1978-84	4.058"			LA-50	4-1/4"	L-50	4-5/16"	6-1/4"
351	1964-74	4-9/16"			LA-409	4-3/4"	L-409	4-13/16"	10-1/4"
351	1960-74	3-15/16"			LA-46G	4-1/8"	L-46G	4-3/16"	7-7/8"
360	1952-54	4-1/8"			LA-402	4-5/16"	L-402	4-3/8"	10-1/4"
366, 6.0 L	1966-97	3-15/16"			LA-45	4-1/8"	L-45	4-3/16"	6-9/16"
378, 6.2 L	1982-95	3.976"			LA-86	4-5/32"	L-86	4-7/32"	6-3/8"
379	1973-75	4.567"			LA-409G	4-3/4"	L-409G	4-13/16"	7-5/8"
6.2 Diesel Flanged repair sleeve	1982-95	4"			FL-3123	4-3/16"	Flanged Sleeve		6-3/4"
395, 6.5 L Diesel	1992-00	4.055"			LA-50B	4-1/4"	L-50B	4-5/16"	6-3/4"
396	1965-69	4.094"			LA-36G	4-9/32"	L-36G	4-11/32"	6-1/4"
400, 6.6 L	1973-80	4-1/8"			LA-52B	4-5/16"	L-52B	4-3/8"	6-3/4"
401	1960-65	4-7/8"			LA-414G	5-1/16"	L-414G	5-1/8"	7-5/8"
402, 6.6 L	1970-72	4-1/8"			LA-67	5-5/16"	L-67	4-3/8"	7-3/4"

CUT TO LENGTH SLEEVES TRUCK - TRACTOR - FORKLIFT



Engine Model	Year	Cyl. Bore	1/16" Wall		3/32" Wall		1/8" Wall		Sleeve Length
			Part No.	O.D.	Part No.	O.D.	Part No.	O.D.	
G. M. C. TRUCKS (Cont.)									
426	1952-55	4-1/4"			LA-404	4-7/16"	L-404	4-1/2"	10-1/4"
427, 7.0 L	1968-94	4-1/4"			LA-53A	4-7/16"	L-53A	4-1/2"	6-1/4"
432	1973-75	4-7/8"			LA-414G	5-1/16"	L-414G	5-1/8"	7-5/8"
454, 7.4 L	1971-00	4-1/4"			LA-63G	4-7/16"	L-63G	4-1/2"	7"
478	1962-77	5-1/8"			LA-502	5-5/16"	L-502	5-3/8"	12-1/4"
496 8.1L	2001-05	4-1/4"			LA-63	4-7/16"	L-63	4-1/2"	7-5/8"
503	1952-67	4-9/16"			LA-409	4-3/4"	L-409	4-13/16"	10-1/4"
702	1960-65	4-9/16"			LA-409G	4-3/4"	L-409G	4-13/16"	7-5/8"
HINO									
H04C 4 cyl	Flanged Replacement Sleeve				FL-3196				
	Block Repair Sleeve 4.214" I.D.				T-3196	4.340"			8"
H06C 6 cyl	Flanged Replacement Sleeve				FL-3197				
	Block Repair Sleeve 4.450" I.D.				T-3197	4.575"			8"
HERCULES									
98, 1.6 L		4"			LA-40	4-3/16	L-40	4-1/4	6"
D5000 White 2-135		4.566"			FL-3193	4.750	Flanged Sleeve		9.670"
INTERNATIONAL									
	1934-39	3-5/16"			LA-35	3-1/2"	L-35	3-9/16"	8"
152	1950-71	3-7/8"			LA-69	4-1/16"	L-69	4-1/8"	6-3/8"
196	1956-71	4-1/8"			LA-67	4-5/16"	L-67	4-3/8"	7-3/4"
214		3-5/16"			LA-35	3-1/2"	L-35	3-9/16"	8"
220	1950-59	3-9/16"			LA-74	3-3/4"	L-74	3-13/16"	8"
232	1969-73	3-3/4"			LA-44	3-15/16"	L-44	4"	7-1/4"
240	1957-69	3-9/16"			LA-26	3-3/4"	L-26	3-13/16"	7-3/4"
264	1955-63	3-11/16"			LA-76	3-7/8"	L-76	3-15/16"	7-5/8"
266	1967-69	3-5/8"			LA-23	3-13/16"	L-23	3-7/8"	6-11/16"
282	1953-63	3-13/16"			LA-77	4"	L-77	4-1/16"	7-5/8"
304	1969-71	3-7/8"			LA-69	4-1/16"	L-69	4-1/8"	6-3/8"
308	1955-63	3-13/16"			LA-77A	4"	L-77A	4-1/16"	8-3/4"
345	1959-78	3-7/8"			LA-707A	4-1/16"	L-707A	4-1/8"	6-3/4"
345	1977-80	3-7/8"			LA-707	4-1/16"	L-707	4-1/8"	7"
354	1963-70	3-7/8"			LA-314	4-1/16"	L-314	4-1/8"	9-1/4"
392	1977-84	4-1/8"			LA-51	4-5/16"	L-51	4-3/8"	6-5/16"
401		4-1/8"			LA-52B	4-5/16"	L-52B	4-3/8"	6-3/4"
404	1977-82	4-1/8"			LA-67	4-5/16"	L-67	4-3/8"	7-3/4"
404	1977-82	4-1/8"			LA-67	4-5/16"	L-67	4-3/8"	7-3/4"
420	1983-87	4"			LA-49	4-3/16"	L-49	4-1/4"	6-7/8"
445	1988-00	4.110"			LA-007	4.297"	L-007	4.360"	8-3/4"
478	1977	4-1/2"			LA-640	4-11/16"	L-640	4-3/4"	8"
501		4-1/2"			LA-408	4-11/16"	L-408	4-3/4"	10-1/4"



CUT TO LENGTH SLEEVES TRUCK - TRACTOR - FORKLIFT

Engine Model	Year	Cyl. Bore	1/16" Wall		3/32" Wall		1/8" Wall		Sleeve Length
			Part No.	O.D.	Part No.	O.D.	Part No.	O.D.	
INTERNATIONAL (Cont.)									
537	1977-81	4-5/8"			LA-410	4-13/16"	L-410	4-7/8"	10-1/4"
549	1956-63	4-1/2"			LA-640	4-11/16"	L-640	4-3/4"	8"
551		4-1/2"			LA-408	4-11/16"	L-408	4-3/4"	10-1/4"
6.9 Litre		4"			LA-49	4-3/16"	L-49	4-1/4"	6-7/8"
7.3 Litre		4.110"			LA-52B	4-5/16"	L-52B	4-3/8"	6-3/4"

INTERNATIONAL FLANGE TYPE SLEEVES

IHC FBB298	Mid 30s	3-3/4"			FL-3165	4.250"			8.420"
7.3 4 Cyl. Diesel		4.110"					FL-3159	4.450"	6-3/4"
D-281		4.125"	*FL-3125	4.248"					10.354"
D-361, DT-361 (Farmall 806-D)		4.125"			*FL-3124	4.313"			8.600"
RD-361		4-1/8"					FL-149	4.500"	8.625"
C-264 (Super M Farmall)	1953	4-1/8"	Flanged Replacement Sleeve Part No.				FL-3215		10-1/8"
RD-450	1952-71	4-3/8"	*FL-150	4.500"	*FL-151	4.5625"	FL-152	4.625"	8.687"
D-407, DT-407		4.321"	*FL-153	4.470"					8.687"
IH-284 (Mazda Engine)	1971-81	70mm	Flanged Replacement Sleeve Part No.				FL-3198	3.150"	5.200"
UD-554		4-5/8"	Flanged Replacement Sleeve Part No.				FL-3200	4.750"	11.755"

*Available overside O.D. +.010, +.020, +.030, +.040 Allow 4 weeks delivery.

ISUZU TRUCK

4 Cyl. Diesel, 3.9 L		4.020"	FL-3163	4.136"	Flanged Replacement Sleeve				8.050"
6 Cyl. NPR		4.135"	T-3163	4.240"	Block Repair Sleeve				8.000"
4.8 L 4HE1-TC 4 Cyl. Turbo Diesel	1999-03	4.333"	Flanged Replacement Sleeve Part No.				FL-3221		

Engine Model	Application	Size	Part No.
--------------	-------------	------	----------

JOHN DEERE

ALL REPAIR RINGS ARE SOLD IN PACKAGES OF 6

466	Upper repair ring semi-bore	5.000" x 5.437" x .600"	CR5437-6
6619	Upper repair ring semi-bore	5.715" x 6.125" x .750"	CR6125-6
164, 219, 329	Lower press fit	4.375" x 4.675" x .750"	LAS4675-6
219, 276, 329	Upper repair ring semi-bore	4.625" x 5.062" x .500"	LAS5062-6

Engine Model	Year	Cyl. Bore	1/16" Wall		3/32" Wall		1/8" Wall		Sleeve Length
			Part No.	O.D.	Part No.	O.D.	Part No.	O.D.	
KUBOTA									
ZB6000C, Diesel semi bore replacement part		72mm	T-56Z	2.959"	LA-56Z	3.022"	L-56Z	3.085"	4.730"
V2203, Diesel		87mm	T-38Z	3.562"					5-3/4"
B6000-Z600		70mm	Flanged Replacement Sleeve Part No.				FL-3199		5.545"
NAVISTAR TRUCKS									
5.7 L, 345	1966-81	3-7/8"			LA-78	4-1/16"	L-78	4-1/8"	6-1/2"
6.7L, 408 Wet	1993-96	4.301"	Flanged Replacement Sleeve Part No.				FL-3194		

CUT TO LENGTH SLEEVES TRUCK - TRACTOR - FORKLIFT



Engine Model	Year	Cyl. Bore	1/16" Wall		3/32" Wall		1/8" Wall		Sleeve Length	
			Part No.	O.D.	Part No.	O.D.	Part No.	O.D.		
NAVISTAR TRUCKS (Cont.)										
7.6L, 466 Wet	2000-03	4.590"	Flanged Replacement Sleeve Part No.				FL-3212			
8.7L, 530 Wet	1997-99	4.590"	Flanged Replacement Sleeve Part No.				FL-3195			
NISSAN FORKLIFT										
1982cc, H20, H20-II		87.2mm 3.433"	T-38	3-9/16"	LA-38	3-5/8"	L-38	3-11/16"	6"	
2974cc, H30		87.2mm 3.433"	T-38	3-9/16"	LA-38	3-5/8"	L-38	3-11/16"	6"	
MACK										
EN510A 6 Cyl.	1954	4-7/16"	Flanged Replacement Sleeve				FL-3187			10.300"
673 Series		4-7/8"	Flanged Replacement Sleeve				FL-3126*			
		5"			LA-500	5-3/16"			12-1/4"	
*Available oversize O.D. +.010, +.020, +.030 Allow 4 weeks delivery.										
MAZDA										
2.0L 122 4 Cyl. Forklift	1979-87	86mm	T-70	3-1/2"	LA-70	3-9/16"	L-70	3-5/8"	7-3/8"	
PERKINS										
4154		3.090"			LA-674	3.253"			6.505"	
4154		3.090"			LA-673	3.263"			6.505"	
4154		3.500"	Flanged Replacement Sleeve				FL-3168	3.814"	7.520"	
152, 203, 305	semi-bore	3.600"	FL-156*		Flanged Replacement Sleeve				8.500"	
152, 203, 305	finish-bore	3.600"	FL-156F		Flanged Replacement Sleeve				8.500"	
236-4		3-7/8"	FL-3127*	4-1/16"	Flanged Replacement Sleeve				8.940"	
*Available oversize O.D. +.010, +.020, +.030 Allow 4 weeks delivery.										
SCANIA										
6 cyl. L.H.S.		5"	Flanged Sleeve		FL-3167	finish-bore			11.450"	
THERMO-KING										
Isuzu C-201		83mm			LA-110138	3.429"			6.485"	
Isuzu 2.2 DI		88mm			LA-110245	3.642"			6.125"	
VOLVO										
D45, TD45, D45B, TD45B 4.5L 273 CID Wet Liner		4.156"	Flanged Replacement Sleeve				FL-3213			
YANMAR										
1600 Wet Liner		85mm	Flanged Replacement Sleeve				FL-3202			6.575"

Engine Model	Year	Cyl. Bore	1/16" Wall		3/32" Wall		1/8" Wall		Sleeve Length
			Part No.	O.D.	Part No.	O.D.	Part No.	O.D.	
AMERICAN MOTORS									
121	1977-79	3.410"			LA-59B	3-19/32"	L-59B	3-21/32"	6-1/4"
150, 2.46 L	1984-90	3.880"			LA-69	4-1/16"	L-69	4-1/8"	6-3/8"
151, 2.5 L	1980-83	4"			LA-40	4-3/16"	L-40	4-1/4"	6"
196	1949-67	3-1/8"			LA-706A	3-5/16"	L-706A	3-3/8"	6-7/8"
199	1965-70	3.750"			LA-39	3-15/16"	L-39	4"	6-7/16"
215, 3.5L	1993	3.779"			LA-28A	3.968"	L-28A	4-1/32"	6"
231, 3.8 L	1978-87	3.800"			LA-25A	3.987"	L-25A	4.050"	6-1/16"
232	1964-79	3-3/4"			LA-39	3-15/16"	L-39	4"	6-7/16"
242, 4.0 L	1987-92	3-7/8"			LA-78	4-1/16"	L-78	4-1/8"	6-1/2"
250	1957-61	3-1/2"	T-20	3-5/8"	LA-20	3-11/16"	L-20	3-3/4"	6"
258, 4.2 L	1971-89	3-3/4"			LA-44	3-15/16"	L-44	4"	7-1/4"
287	1963-66	3.750"			LA-39	3-15/16"	L-39	4"	6-7/16"
290	1966-69	3.750"			LA-39	3-15/16"	L-39	4"	6-7/16"
304, 5.0 L	1970-79	3-3/4"			LA-39	3-15/16"	L-39	4"	6-7/16"
327	1956-69	4"			LA-40	4-3/16"	L-40	4-11/32"	7"
343	1967-69	4.080"			LA-705	4-9/32"	L-705	4-11/32"	7"
360, 5.9 L	1967-83	4.080"			LA-705	4-9/32"	L-705	4-11/32"	7"
390, 401	1970-76	4.165"			LA-80	4-3/8"	L-80	4-7-16"	6-3/4"
BUICK									
112, 1.8 L	1982	3-1/2"	T-20	3-5/8"	LA-20	3-11/16"	L-20	3-3/4"	6"
112, 1.8 L	1982-86	3.340"	T-270	3.471"	LA-270	3.533"	L-270	3.596"	6-3/16"
121, 2.0 L	1982-89	3-1/2"	T-20	3-5/8"	LA-20	3-11/16"	L-20	3-3/4"	6"
122, 2.0 L	1987-88	3.385"	T-70D	3-1/2"	LA-70D	3-9/16"	L-70D	3-5/8"	6-1/2"
133, 2.2 L	1993-96	3-1/2"			LA-708	3-11/16"	L-708	3-3/4"	6-3/4"
138, 2.3 L	1987-95	3-5/8"			LA-23	3-13/16"	L-23	3-7/8"	6-11/16"
151, 2.5 L	1980-92	4"			LA-40	4-3/16"	L-40	4-1/4"	6"
173, 2.8 L	1981-90	3-1/2"	T-20	3-5/8"	LA-20	3-11/16"	L-20	3-3/4"	6"
181, 3.0 L	1982-88	3.800"			LA-25A	3.987"	L-25A	4.050"	6-1/16"
191, 3.1 L	1989-99	3-1/2"	T-20	3-5/8"	LA-20	3-11/16"	L-20	3-3/4"	6"
196	1978-79	3-1/2"	T-20	3-5/8"	LA-20	3-11/16"	L-20	3-3/4"	6"
198	1954-63	3-5/8"			LA-24	3-13/16"	L-24	3-7/8"	6"
204, 3.3 L	1989-95	3.700"			LA-37D	3.8875"	L-37D	3.950"	6-3/8"
215	1978	3-1/2"	T-20	3-5/8"	LA-20	3-11/16"	L-20	3-3/4"	6"
225	1964-67	3-3/4"			LA-39A	3-15/16"	L-39A	4"	6"
231, 3.8 L	1975-05	3.800"			LA-25A	3.9875"	L-25A	4.050"	6-1/16"
250	1968-76	3-7/8"			LA-69	4-1/16"	L-69	4-1/8"	6-3/8"
250, 4.1 L	1982-85	3.465"	T-272	3.590"	LA-272	3.642"	L-272	3.715"	6"
252, 4.1 L	1980-84	3.970"			LA-86	4-5/32"	L-86	4-7/32"	6-3/8"
260L	1975-76	3-1/2"	T-20	3-5/8"	LA-20	3-11/16"	L-20	3-3/4"	6"
262, 4.3 L	1983-85	4-1/16"			LA-50	4-1/4"	L-50	4-5/16"	6-1/4"
262, 4.3 L	1992-95	3.736"			LA-87	3-59/64"	L-87	3-63/64"	6-3/8"
265	1981	3-3/4"			LA-39A	3-15/16"	L-39A	4"	6"
300	1964-67	3-3/4"			LA-39A	3-15/16"	L-39A	4"	6"
301, 5.0 L	1977-81	4"			LA-40	4-3/16"	L-40	4-1/4"	6"
305, 5.0 L	1977-93	3.736"			LA-87	3-59/64"	L-87	3-63/64"	6-3/8"
307, 5.0 L	1981-90	3.800"			LA-25A	3.987"	L-25A	4.050"	6-1/16"
322	1953-56	4"			LA-40	4-3/16"	L-40	4-1/4"	6"

CUT TO LENGTH SLEEVES AMERICAN CARS



Engine Model	Year	Cyl. Bore	1/16" Wall		3/32" Wall		1/8" Wall		Sleeve Length
			Part No.	O.D.	Part No.	O.D.	Part No.	O.D.	
BUICK (Cont.)									
340	1964-67	3-3/4"			LA-39B	4-15/16"	L-39B	4"	6-1/8"
350X, 5.7 L	1968-81	3.800"			LA-25	3.9875"	L-25	4.050"	6-7/8"
350L, 5.7 L	1953-92	4"			LA-40	4-3/16"	L-40	4-1/4"	6"
350N, 5.7 L	1977-85	4.057"			LA-50	4-1/4"	L-50	4-5/16"	6-1/4"
364	1957-61	4-1/8"			LA-51	4-5/16"	L-51	4-3/8"	6-5/16"
400	1967-69	4.040"			LA-60	4-15/64"	L-60	4-19/64"	6-3/8"
400	1957-61	4-1/8"			LA-52A	4-5/16"	L-52A	4-3/8"	6-5/8"
401	1959-69	4-3/16"			LA-57	4-3/8"	L-57	4-7/16"	7"
403, 6.6 L	1977-81	4.351"			LA-73	4-35/64"	L-73	4-39/64"	6-7/8"
425	1963-71	4-5/16"			LA-58	4-1/2"	L-58	4-9/16"	7-1/4"
430	1959-69	4-3/16"			LA-57	4-3/8"	L-57	4-7/16"	7"
455	1963-76	4-5/16"			LA-58	4-1/2"	L-58	4-9/16"	7-1/4"
CADILLAC									
112, 1.8 L	1982	3-1/2"	T-20	3-5/8"	LA-20	3-11/16"	L-20	3-3/4"	6"
112, 1.8 L	1982-85	3.340"	T-270	3.471"	LA-270	3.533"	L-270	3.596"	6-3/16"
121, 2.0 L	1982-86	3-1/2"	T-20	3-5/8"	LA-20	3-11/16"	L-20	3-3/4"	6"
173, 2.8 L	1985-88	3-1/2"	T-20A	3-5/8"	LA-20A	3-11/16"	L-20A	3-3/4"	5-5/16"
250, 4.1 L	1982-88	3.465"	T-272	3.590"	LA-272	3.642"	L-272	3.715"	6"
252, 4.1 L	1980-83	3.970"			LA-86	4-5/32"	L-86	4-7/32"	6-3/8"
273, 4.5 L	1988-92	3-5/8"			LA-24	3-13/16"	L-24	3-7/8"	6"
300, 4.9 L	1991-95	3-5/8"			LA-24	3-13/16"	L-24	3-7/8"	6"
305, 5.0 L	1991-92	3.736"			LA-87	3-59/64"	L-87	3-63/64"	6-3/8"
307, 5.0 L	1986-90	3.800"			LA-25A	3.987"	L-25A	4.050"	6-1/6"
331	1949-55	3-13/16"			LA-42	4"	L-42	4-1/16"	6-7/8"
350, 5.7 L	1975-85	4.057"			LA-50	4-1/4"	L-50	4-5/16"	6-1/4"
350, 5.7 L	1990-00	4"			LA-40	4-3/16"	L-40	4-1/4"	6"
365	1956-57	4"			LA-49	4-3/16"	L-49	4-1/4"	6-7/8"
368, 6.0 L	1980-84	3.800"			LA-25	3.9875"	L-25	4.050"	6-7/8"
390	1956-64	4"			LA-49	4-3/16"	L-49	4-1/4"	6-7/8"
425	1977-79	4.082"			LA-36G	4.281"	L-36G	4.344"	6-1/4"
429	1964-67	4-1/8"			LA-52	4-5/16"	L-52	4-3/8"	7-1/4"
472	1968-76	4.300"			LA-54B	4.487"	L-54B	4.550"	7"
500	1968-76	4.300"			LA-54B	4.487"	L-54B	4.550"	7"
CHEVROLET									
	1929-36	3-5/16"	T-607	3-7/16"	LA-607	3-1/2"	L-607	3-9/16"	7-9/16"
61, 1.0 L	1985-99	2.913"	T-245	3.038"	LA-245	3.100"	L-245	3.163"	6-1/2"
79, 1.3 L	1995-97	2.913"	T-245	3.038"	LA-245	3.100"	L-245	3.163"	6-1/2"
85, 1.4 L	1976-77	3.228"	T-002	3.353"	LA-002	3.415"	L-002	3.478"	6"
92, 1.5 L	1985-89	3.031"	T-860	3-5/32"	LA-860	3-7/32"	L-860	3-9/32"	6-1/8"
97, 1.6 L	1993-98	3-3/16"	T-603A	3-5/16"	LA-603A	3-3/8"	L-603A	3-7/16"	6"
98, 1.6 L	1976-87	3.228"			LA-002	3.415"	L-002	3.478"	6"
98, 1.6 L	1985-92	3.187"	T-603	3-5/16"	LA-603	3-3/8"	L-603	3-7/16"	6-1/2"
110, 1.8 L	1981-84	3.310"	T-607C	3-7/16"	LA-607C	3-1/2"	L-607C	3-9/16"	6-5/8"
110, 1.8 L	1993-97	3-3/16"	T-603A	3-5/16"	LA-603A	3-3/8"	L-603A	3-7/16"	6"
112, 1.8 L	1982	3-1/2"	T-20	3-5/8"	LA-20	3-11/16"	L-20	3-3/4"	6"
112, 1.8 L	1982-85	3.340"	T-270	3.471"	LA-270	3.533"	L-270	3.596"	6-3/16"
121, 2.0 L	1982-90	3-1/2"	T-20	3-5/8"	LA-20	3-11/16"	L-20	3-3/4"	6"

Engine Model	Year	Cyl. Bore	1/16" Wall		3/32" Wall		1/8" Wall		Sleeve Length
			Part No.	O.D.	Part No.	O.D.	Part No.	O.D.	
CHEVROLET (Cont.)									
121, 2.0 L	1991-95	3.385"	T-70D	3-1/2"	LA-70D	3-9/16"	L-70D	3-5/8"	6-1/2"
133, 2.2 L	1990-97	3-1/2"			LA-708	3-11/16"	L-708	3-3/4"	6-3/4"
138, 2.3 L	1987-95	3-5/8"			LA-24	3-13/16"	L-24	3-7/8"	6"
140, 2.3 L	1971-77	3-1/2"	T-20	3-5/8"	LA-20	3-11/16"	L-20	3-3/4"	6"
151, 2.5 L	1978-92	4"			LA-40	4-3/16"	L-40	4-1/4"	6"
153	1957-71	3-7/8"			LA-68	4-1/16"	L-68	4-1/8"	6"
173, 2.8 L	1979-89	3-1/2"	T-20	3-5/8"	LA-20	3-11/16"	L-20	3-3/4"	6"
181, 3.0 L	1982-87	3.800"			LA-25A	3.987"	L-25A	4.050"	6"
191, 3.1 L	1988-99	3-1/2"	T-20	3-5/8"	LA-20	3-11/16"	L-20	3-3/4"	6"
194	1962-68	3-9/16"			LA-21A	3-3/4"	L-21A	3-13/16"	6"
196	1978-79	3-1/2"	T-20	3-5/8"	LA-20	3-11/16"	L-20	3-3/4"	6"
200, 3.3 L	1978-79	3-1/2"	T-20	3-5/8"	LA-20	3-11/16"	L-20	3-3/4"	6"
207, 3.4 L	1991-05	3.622"			LA-24	3-13/16"	L-24	3-7/8"	6"
216	1937-53	3-1/2"	T-608	3-5/8"	LA-608	3-11/16"	L-608	3-3/4"	7-1/8"
229, 3.8 L	1980-84	3.736"			LA-87	3-59/64"	L-87	3-63/64"	6-3/8"
230	1957-71	3-7/8"			LA-68	4-1/16"	L-68	4-1/8"	6"
231, 3.8 L	1978-05	3.800"			LA-25A	3.987"	L-25A	4.050"	6-1/16"
235	1950-66	3-9/16"	T-608A	3-11/16"	LA-608A	3-3/4"	L-608A	3-13/16"	7-1/4"
250, 4.1 L	1966-79	3-7/8"			LA-78	4-1/16"	L-78	4-1/8"	6-1/2"
261	1955-57	3-3/4"			LA-44	3-15/16"	L-44	4"	7-1/4"
262	1975-76	3.671"			LA-88	3-55/64"	L-88	3-59/64"	5-1/2"
262, 4.3 L	1982-85	4.057"			LA-50	4-1/4"	L-50	4-5/16"	6-1/4"
262, 4.3 L	1985-05	4"			LA-40	4-3/16"	L-40	4-1/4"	6"
262, 4.3 L	1992-95	3.736"			LA-87	3-59/64"	L-87	3-63/64"	6-3/8"
265	1955-57	3-3/4"			LA-39A	3-15/16"	L-39A	4"	6"
265, 4.3 L	1994-96	3.736"			LA-87	3-59/64"	L-87	3-63/64"	6-3/8"
267, 4.4 L	1979-82	3-1/2"	T-20	3-5/8"	LA-20	3-11/16"	L-20	3-3/4"	6"
283	1957-71	3-7/8"			LA-68	4-1/16"	L-68	4-1/8"	6"
292, 4.8 L	1964-89	3-7/8"			LA-707	4-1/16"	L-707	4-1/8"	7"
302	1962-74	4"			LA-40	4-3/16"	L-40	4-1/4"	6"
305, 5.0 L	1976-93	3.736"			LA-87	3-59/64"	L-87	3-63/64"	6-3/8"
305		4"			FL-3133D	4.200"	FLANGE SLEEVE		6"
305		4"			FLANGE SLEEVE		FL-3135D	4.253"	6"
307, 5.0 L	1968-78	3-7/8"			LA-78	4-1/16"	L-78	4-1/8"	6-1/2"
307, 5.0 L	1985-90	3.800"			LA-25A	3.9875"	L-25A	4.050"	6"
327	1962-74	4"			LA-40	4-3/16"	L-40	4-1/4"	6"
348, 5.7 L	1958-70	4-1/8"			LA-52	4-5/16"	L-52	4-3/8"	7-1/4"
350, 5.7 L	1962-97	4"			LA-40	4-3/16"	L-40	4-1/4"	6"
350, 5.7 L	1980-85	4.057"			LA-50	4-1/4"	L-50	4-5/16"	6-1/4"
350, 5.7 L	1990-94	3.897"			LA-90A	4.087"	L-90A	4.150"	6-1/2"
LS1 Corvette		3.900"			FLANGE SLEEVE		FL-3189	4.255"	5.525"
LS1 Corvette Big Bore		4.100"			FLANGE SLEEVE		FL-3188	4.255"	5.525"
366, 6.0 L	1957-69	3-15/16"			LA-45	4-1/8"	L-45	4-3/16"	6-9/16"
378, 6.2 L	1982-89	3.976"			LA-862	4.163"	L-862	4.226"	6-9/16"
396	1967	4-1/16"			LA-50	4-1/4"	L-50	4-5/16"	6-1/4"
396	1965-71	4.094"			LA-36	4-9/32"	L-36	4-11/32"	6-1/16"
400, 6.6 L	1970-80	4-1/8"			LA-52B	4-5/16"	L-52B	4-3/8"	6-3/4"

CUT TO LENGTH SLEEVES AMERICAN CARS

L.A. SLEEVE

Engine Model	Year	Cyl. Bore	1/16" Wall		3/32" Wall		1/8" Wall		Sleeve Length
			Part No.	O.D.	Part No.	O.D.	Part No.	O.D.	
CHEVROLET (Cont.)									
400, 6.6 L		4-1/8"			FL-3137D	4-5/16"	FLANGE SLEEVE		6-3/4"
400, 6.6 L		4-1/8"			FLANGE SLEEVE		FL-3138D	4-3/8"	6-3/4"
402	1970-76	4-1/8"			LA-52B	4-5/16"	L-52B	4-3/8"	6-3/4"
409	1961-65	4-5/16"			LA-58	4-1/2"	L-58	4-9/16"	7-1/4"
427, 7.0 L	1966-76	4-1/4"			LA-53A	4-7/16"	L-53A	4-1/2"	6-1/4"
ZL1 Corvette		4-1/4"			FLANGE SLEEVE		FL-3179	4.550"	6.240"
454, 7.4 L	1966-89	4-1/4"			LA-53A	4-7/16"	L-53A	4-1/2"	6-1/4"
CHRYSLER									
90, 1.5 L	1985-96	2.968"	T-248	3.093"	LA-248	3.156"	L-248	3.218"	6-1/2"
97, 1.6 L	1982-86	3.175"	T-603	3-5/16"	LA-603	3-3/8"	L-603	3-7/16"	6-1/2"
105, 1.7 L	1978-83	3.130"	T-706A	3-1/4"	LA-706A	3-5/16"	L-706A	3-3/8"	6-7/8"
105, 1.7 L	1985-87	3.188"	T-603	3-5/16"	LA-603	3-3/8"	L-603	3-7/16"	6-1/2"
107, 1.8 L	1989-94	3.173"	T-361	3.295"	LA-361	3.357"	L-361	3.420"	6-1/2"
112, 1.8 L	1991-97	3.188"	T-603	3-5/16"	LA-603	3-3/8"	L-603	3-7/16"	6-1/2"
122, 2.0 L	1983-98	3.346"	T-270	3.471"	LA-270	3.533"	L-270	3.596"	6-3/16"
135, 2.2 L	1981-95	3.445"			LA-38	3-5/8"	L-38	3-11/16"	6"
144, 2.4 L	1992-96	3.406"	T-59	3.525"	LA-59	3.587"	L-59	3.650"	7"
148, 2.4 L	1995-00	3.445"	T-38	3-9/16"	LA-38	3-5/8"	L-38	3-11/16"	6"
153, 2.5 L	1986-95	3.445"	T-38	3-9/16"	LA-38	3-5/8"	L-38	3-11/16"	6"
156, 2.6 L	1978-89	3.590"			LA-005	3.769"	L-005	3.832"	6-1/4"
167, 2.7 L	1998-00	3.386"	T-286B	3.516"	LA-286B	3.587"	L-286B	3.650"	6-1/2"
181, 3.0 L	1986-00	3.586"			LA-005	3.769"	L-005	3.832"	6-1/4"
183, 3.0 L	1991-96	3.586"			LA-005	3.769"	L-005	3.832"	6-1/4"
201, 3.3 L	1990-00	3.661"	T-353	3.786"	LA-353	3.848"	L-353	3.911"	6-1/2"
215, 3.5 L	1993-00	3.781"			LA-28A	3.968"	L-28A	4-1/32"	6"
218	1934-54	3-1/4"	T-605	3-3/8"	LA-605	3-7/16"	L-605	3-1/2"	8-1/8"
225, 3.7 L	1960-87	3.400"	T-59	3.525"	LA-59	3.587"	L-59	3.650"	7"
230	1942-59	3-1/4"	T-605	3-3/8"	LA-605	3-7/16"	L-605	3-1/2"	8-1/8"
231, 3.8 L	1991-00	3.781"			LA-28A	3.968"	L-28A	4-1/32"	6"
238, 3.9 L	1986-00	3.910"			LA-55	4.097"	L-55	4.160"	6-1/16"
242, 4.0 L	1987-92	3-7/8"			LA-78	4-1/16"	L-78	4-1/8"	6-1/2"
230	1942-59	3-1/4"	T-605	3-3/8"	LA-605	3-7/16"	L-605	3-1/2"	8-1/8"
251	1942-54	3-7/16"			LA-701	3-5/8"	L-701	3-11/16"	8-1/8"
273	1964-69	3-5/8"			LA-24	3-13/16"	L-24	3-7/8"	6"
318, 5.2 L	1957-00	3.910"			LA-55	4.097"	L-55	4.160"	6-1/16"
331	1951-56	3-13/16"			LA-43	4"	L-43	4-1/16"	6-5/8"
354	1956-58	3-15/16"			LA-46	4-1/8"	L-46	4-3/16"	6-7/8"
360, 5.9 L	1971-00	4"			LA-40A	4-3/16"	L-40A	4-1/4"	6-1/4"
361	1958-66	4-1/8"			LA-51	4-5/16"	L-51	4-3/8"	6-5/16"
383	1959-60	4-1/32"			LA-72	4-7/32"	L-72	4-9/32"	7"
383	1959-71	4-1/4"			LA-53	4-7/16"	L-53	4-1/2"	6-5/8"
392	1957-58	4"			LA-49	4-3/16"	L-49	4-1/4"	6-7/8"
400, 6.6 L	1972-78	4.342"			LA-83	4.530"	L-83	4.592"	6-1/4"
413	1959-69	4-3/16"			LA-57	4-3/8"	L-57	4-7/16"	7"
440, 7.2 L	1966-78	4.320"			LA-65	4-1/2"	L-65	4-9/16"	6-3/4"

Engine Model	Year	Cyl. Bore	1/16" Wall		3/32" Wall		1/8" Wall		Sleeve Length
			Part No.	O.D.	Part No.	O.D.	Part No.	O.D.	
DODGE									
86, 1.4 L	1980-85	2.913"	T-245	3.038"	LA-245	3.100"	L-245	3.163"	6-1/2"
90, 1.5 L	1985-96	2.968"	T-248	3.093"	LA-248	3.156"	L-248	3.218"	6-1/2"
97, 1.6 L	1982-86	3.175"	T-603	3-5/16"	LA-603	3-3/8"	L-603	3-7/16"	6-1/2"
98, 1.6 L	1973-84	3.028"	T-860	3-5/32"	LA-860	3-7/32"	L-860	3-9/32"	6-1/8"
98, 1.6 L	1981-83	3.568"	T-21A	3-11/16"	LA-21A	3-3/4"	L-21A	3-13/16"	6"
105, 1.7 L	1978-83	3.130"	T-706A	3-1/4"	LA-706A	3-5/16"	L-706A	3-3/8"	6-7/8"
105, 1.7 L	1985-87	3.188"	T-603	3-5/16"	LA-603	3-3/8"	L-603	3-7/16"	6-1/2"
107, 1.8 L	1989-94	3.173"	T-361	3.295"	LA-361	3.357"	L-361	3.420"	6-1/2"
112, 1.8 L	1991-97	3.188"	T-603	3-5/16"	L-603	3-3/8"	L-603	3-7/16"	6-1/2"
122, 2.0 L	1974-82	3.307"	T-281	3-7/16"	LA-281	3-1/2"	L-281	3-9/16"	6-1/2"
122, 2.0 L	1983-98	3.346"	T-270	3.471"	L-270	3.533"	L-270	3.596"	6-3/16"
135, 2.2 L	1981-95	3.445"			LA-38	3-5/8"	L-38	3-11/16"	6"
146, 2.4 L	1989-96	3.406"	T-59	3.525"	LA-59	3.587"	L-59	3.650"	7"
153, 2.5 L	1986-95	3.445"	T-38	3-9/16"	LA-38	3-5/8"	L-38	3-11/16"	6"
156, 2.6 L	1978-89	3.590"			LA-005	3.769"	L-005	3.832"	6-1/4"
170	1960-71	3.400"	T-59A	3.525"	LA-59A	3.587"	L-59A	3.650"	6"
181, 3.0 L	1986-00	3.586"			LA-005	3.769"	L-005	3.832"	6-1/4"
183, 3.0 L	1991-96	3.590"			LA-005	3.769"	L-005	3.832"	6-1/4"
198	1970-74	3.400"	T-59	3.525"	LA-59	3.587"	L-59	3.650"	7"
201, 3.3 L	1990-00	3.661"	T-353	3.786"	LA-353	3.848"	L-353	3.911"	6-1/2"
215, 3.5 L	1993-00	3.779"			LA-28A	3.968"	L-28A	4-1/32"	6"
218	1934-54	3-1/4"	T-605	3-3/8"	LA-605	3-7/16"	L-605	3-1/2"	8-1/8"
225, 3.7 L	1960-87	3.400"	T-59	3.525"	LA-59	3.587"	L-59	3.650"	7"
228	1940	3-3/8"			LA-700	3-9/16"	L-700	3-5/8"	8-1/8"
230	1942-60	3-1/4"			LA-605	3-7/16"	L-605	3-1/2"	8-1/8"
231, 3.8 L	1991-00	3.779"			LA-28A	3.968"	L-28A	4-1/32"	6"
238, 3.9 L	1986-00	3.910"			LA-55	4.097"	L-55	4.160"	6-1/16"
241	1938-41	3-3/8"	T-70D	3-1/2"	LA-70D	3-9/16"	L-70D	3-5/8"	6-1/2"
241	1953-55	3-7/16"			LA-38	3-5/8"	L-38	3-11/16"	6"
242, 4.0 L	1987-92	3-7/8"			LA-78	4-1/16"	L-78	4-1/8"	6-1/2"
265	1942-69	3-7/16"			LA-701	3-5/8"	L-701	3-11/16"	8-1/8"
270	1955-56	3-5/8"			LA-24	3-13/16"	L-24	3-7/8"	6"
273	1964-69	3-5/8"			LA-24	3-13/16"	L-24	3-7/8"	6"
277	1956-57	3-3/4"			LA-39A	3-15/16"	L-39A	4"	6"
301	1957	3.910"			LA-55	4.097"	L-55	4.160"	6-1/16"
303	1956-57	3-16/16"			LA-43	4"	L-43	4-1/16"	6-5/8"
315	1956	3-5/8"			LA-23	3-13/16"	L-23	3-7/8"	6-11/16"
318, 5.2 L	1957-00	3.910"			LA-55	4.097"	L-55	4.160"	6-1/16"
325	1957-58	3-11/16"			LA-37	3-7/8"	L-37	3-15/16"	6-5/8"
326	1959	3.950"			LA-006	3.137"	L-006	4.200"	6-7/8"
340	1968-73	4.040"			LA-60	4-15/64"	L-60	4-19/64"	6-3/8"
350	1958	4-1/16"			LA-50	4-1/4"	L-50	4-5/16"	6-1/4"
359, 5.9 L	1971-00	4"			LA-40A	4-3/16"	L-40A	4-1/4"	6-1/4"
361	1958-66	4-1/8"			LA-51	4-5/16"	L-51	4-3/8"	6-5/16"
383	1959-71	4-1/4"			LA-53	4-7/16"	L-53	4-1/2"	6-5/8"
400, 6.6 L	1972-78	4.342"			LA-83	4.530"	L-83	4.592"	6-1/4"
413	1959-77	4-3/16"			LA-57	4-3/8"	L-57	4-7/16"	7"
426	1951-71	4-1/4"			LA-53B	4-7/16"	L-53B	4-1/2"	6-7/8"
440, 7.2 L	1966-81	4.320"			LA-65	4-1/2"	L-65	4-9/16"	6-3/4"
Viper V-10 Wet Liner	1995-04	4.030"	Flanged Replacement Sleeve Part No. FL-3210						5.907"

CUT TO LENGTH SLEEVES AMERICAN CARS

L.A. SLEEVE

Engine Model	Year	Cyl. Bore	1/16" Wall		3/32" Wall		1/8" Wall		Sleeve Length
			Part No.	O.D.	Part No.	O.D.	Part No.	O.D.	
EAGLE									
122, 2.0 L	1990-94	3.346"	T-270	3.471"	LA-270	3.533"	L-270	3.569"	6-3/16"
143, 2.4 L	1992-96	3.405"	T-59	3.525"	LA-59	3.587"	L-59	3.650"	7"
201, 3.3 L	1993-94	3.661"	T-353	3.786"	LA-353	3.848"	L-353	3.911"	6-1/2"
FORD									
A, AA, B, BB	1928-34	3-7/8"			LA-609	4-1/16"	L-609	4-1/8"	7-1/2"
80, 1.3 L	1988-97	2.795"	T-291A	2.920"	LA-291A	2.982"	L-291A	3.045"	6"
97.6	1981	3.150"	T-89	3-9/32"	LA-89	3-11/32"	L-89	3-13/32"	6"
97.6, 1.6 L	1981-85	3.150"	T-254	3.275"	LA-254	3.337"	L-254	3.399"	6-1/2"
98, 1.6 L	1987-94	3.070"	T-602	3-3/16"	LA-602	3-1/4"	L-602	3-5/16"	6-1/2"
98, 1.6 L	1978-80	3.190"	T-603A	3-5/16"	LA-603A	3-3/8"	L-603A	3-7/16"	6"
112, 1.8 L	1991-96	3.287"	T-260	3.407"	LA-260	3.468"	L-260	3.530"	6-1/2"
116, 1.9 L	1985-96	3.228"			LA-002	3.415"	L-002	3.478"	6"
120, 2.0 L	1984-85	3.390"	T-59A	3.525"	LA-59A	3.587"	L-59A	3.650"	6"
122, 2.0 L	1971-74	3.580"	T-82	3.705"	LA-82	3.767"	L-82	3.830"	5-3/8"
122, 2.0 L	1984-88	3.386"	T-286	3.516"	LA-286	3.578"	L-286	3.641"	5-1/4"
122, 2.0 L	1993-95	3.267"	T-288	3.392"	LA-288	3.454"	L-288	3.517"	6-1/4"
133, 2.2 L	1988-93	3.386"	T-286	3.516"	LA-286	3.578"	L-286	3.641"	5-1/4"
140, 2.3 L	1974-94	3.781"	T-28A	3.906"	LA-28A	3.968"	L-28A	4-1/32"	6"
140, 2.3 L	1984-94	3.687"			LA-37	3-7/8"	L-37	3-15/16"	6-5/8"
142, 2.3 L	1990-95	3.708"			LA-37D	3.887"	L-37D	3.950"	6-3/8"
144	1961-72	3-1/2"	T-20A	3-5/8"	LA-20A	3-11/16"	L-20A	3-3/4"	5-5/16"
153, 2.5 L	1986-91	3.661"			LA-85	3.847"	L-85	3.910"	6-1/2"
153, 2.5 L	1993-95	3.330"	T-270	3.471"	LA-270	3.533"	L-270	3.596"	6-3/16"
154, 2.5 L	1990-91	3.687"			LA-37	3-7/8"	L-37	3-15/16"	6-5/8"
170	1961-72	3-1/2"	T-20A	3-5/8"	LA-20A	3-11/16"	L-20A	3-3/4"	5-5/16"
171, 2.8 L	1974-87	3.660"			LA-85	3.847"	L-85	3.910"	6-1/2"
172	1974-80	3.900"			LA-90	4.087"	L-90	4.150"	7"
177, 2.9 L	1986-90	3.661"			LA-85	3.847"	L-85	3.910"	6-1/2"
181, 3.0 L	1993-96	3.425"	T-265-C	3-9/16"	LA-265-C	3-5/8"	L-265-C	3-11/16"	6.150"
182, 3.0 L	1986-05	3-1/2"			LA-20	3-11/16"	L-20	3-3/4"	6"
182, 3.0 L	1996-99	3.244"	T-34A	3-3/8"	LA-34A	3-7/16"	L-34A	3-1/2"	6-1/2"
183, 3.0 L	1990-05	3.503"	T-20	3-5/8"	LA-20	3-11/16"	L-20	3-3/4"	6"
185	1932-41	3-1/16"	T-602	3-3/16"	LA-602	3-1/4"	L-602	3-5/16"	6-1/2"
195	1946-53	3-3/16"	T-603	3-5/16"	LA-603	3-3/8"	L-603	3-7/16"	6-1/2"
195, 3.2 L	1993-95	3.620"			LA-24	3-13/16"	L-24	3-7/8"	6"
200, 3.3 L	1963-83	3-11/16"			LA-37A	3-7/8"	L-37A	3-15/16"	5-1/8"
207, 3.4 L	1996	3.246"	T-34A	3-3/8"	LA-34A	3-7/16"	L-34A	3-1/2"	6-1/2"
215	1952-53	3-9/16"			LA-21	3-3/4"	L-21	3-13/16"	6-11/16"
221	1961-72	3-1/2"	T-20A	3-5/8"	LA-20A	3-11/16"	L-20A	3-3/4"	5-5/16"
223	1954-64	3-5/8"			LA-23	3-13/16"	L-23	3-7/8"	6-11/16"
226H	1948-57	3.300"			LA-606	3.487"	L-606	3.550"	8-1/4"
232, 3.8 L	1982-00	3-13/16"			LA-43	4"	L-43	4-1/16"	6-5/8"
232, 3.8 L	1983-85	3.800"			LA-25A	3.987"	L-25A	4.050"	6-1/16"
239	1939-53	3-3/16"	T-603	3-5/16"	LA-603	3-3/8"	L-603	3-7/16"	6-1/2"
239	1954	3-1/2"	T-20	3-5/8"	LA-20	3-11/16"	L-20	3-3/4"	6"
240, 3.9 L	1958-78	4"			LA-40A	4-3/16"	L-40A	4-1/4"	6-1/4"
250, 4.1 L	1969-83	3.687"			LA-37	3-7/8"	L-37	3-15/16"	6-5/8"
254	1954-55	3-1/2"			LA-710	3-11/16"	L-710	3-3/4"	8-1/4"

Engine Model	Year	Cyl. Bore	1/16" Wall		3/32" Wall		1/8" Wall		Sleeve Length
			Part No.	O.D.	Part No.	O.D.	Part No.	O.D.	
FORD (Cont.)									
255	1949-53	3-3/16"	T-603	3-5/16"	LA-603	3-3/8"	L-603	3-7/16"	6-1/2"
255, 4.2 L	1980-82	3.687"			LA-37A	3-7/8"	L-37A	3-15/16"	5-1/8"
256	1954	3-5/8"			LA-24	3-13/16"	L-24	3-7/8"	6"
260	1962-71	3.800"			LA-25B	3.987"	L-25B	4.050"	5-1/8"
272	1955-58	3-5/8"			LA-24	3-13/16"	L-24	3-7/8"	6"
4605cc, 4.6 L	1996	3.543"	T-273	3.668"	LA-273	3.730"	L-273	3.793"	6-1/2"
281, 4.6 L	1991-05	3.551"			LA-273	3.730"	L-273	3.793"	6-1/2"
289, 4.7 L	1958-78	4"			LA-40B	4-3/16"	L-40B	4-1/4"	5-1/8"
292	1955-64	3-3/4"			LA-39A	3-15/16"	L-39A	4"	6"
302, 5.0 L	1968-95	4"			LA-40B	4-3/16"	L-40B	4-1/4"	5-1/8"
312	1956-60	3.800"			LA-25A	3.987"	L-25A	4.050"	6-1/16"
330	1964-69	3-7/8"			LA-69	4-1/16"	L-69	4-1/8"	6-3/8"
332	1956-57	3.800"			LA-25	3.987"	L-25	4.050"	6-7/8"
332	1958-78	4"			LA-40A	4-3/16"	L-40A	4-1/4"	6-1/4"
351, 5.8 L	1969-91	4"			LA-40A	4-3/16"	L-40A	4-1/4"	6-1/4"
352	1958-66	4"			LA-40A	4-3/16"	L-40A	4-1/4"	6-1/4"
361	1958-59	4.050"			LA-60	4-15/64"	L-60A	4-19/64"	6-3/8"
390	1961-71	4.040"			LA-60	4-15/64"	L-60	4-19/64"	6-3/8"
400, 6.6 L	1971-82	4"			LA-41	4-3/16"	L-41	4-1/4"	6-5/8"
406	1963-70	4-1/8"			LA-52C	4-5/16"	L-52C	4-3/8"	7-1/2"
410	1966-67	4.050"			LA-60	4-15/64"	L-60	4-19/64"	6-3/8"
427	1963-69	4-15/64"			LA-22	4-27/64"	L-22	4-31/64"	6-1/4"
428	1963-70	4-1/8"			LA-51	4-5/16"	L-51	4-3/8"	6-5/16"
429	1968-74	4-23/64"			LA-73	4-35/64"	L-73	4-39/64"	6-7/8"
430	1963-64	4.300"			LA-54	4.487"	L-54	4.550"	7-9/16"
460, 7.5 L	1968-78	4-23/64"			LA-73	4-35/64"	L-73	4-39/64"	6-7/8"
JEEP									
134	1938-73	3-1/8"			LA-706	3-5/16"	L-706	3-3/8"	8-1/8"
150, 2.46 L	1983-00	3-7/8"			LA-69	4-1/16"	L-69	4-1/8"	6-3/8"
151, 2.5 L	1980-83	4"			LA-40	4-3/16"	L-40	4-1/4"	6"
161	1951-56	3-1/8"	T-706A	3-1/4"	LA-706A	3-5/16"	L-706A	3-3/8"	6-7/8"
173, 2.8 L	1984-86	3-1/2"	T-20A	3-5/8"	LA-20A	3-11/16"	L-20A	3-3/4"	5-5/16"
225	1965-71	3-3/4"			LA-39	3-15/16"	L-39	4"	6-7/16"
226	1954-67	3-5/16"			LA-607	3-1/2"	L-607	3-9/16"	7-9/16"
230	1963-70	3-11/32"			LA-62	3-17/32"	L-62	3-19/32"	7-1/2"
232	1965-78	3-3/4"			LA-44	3-15/16"	L-44	4"	7-1/4"
242, 4.0 L	1987-00	3-7/8"			LA-69	4-1/16"	L-69	4-1/8"	6-3/8"
258, 4.2 L	1971-90	3-3/4"			LA-44	3-15/16"	L-44	4"	7-1/4"
304, 5.0 L	1971-82	3-3/4"			LA-39	3-15/16"	L-39	4"	6-7/16"
318, 5.2 L	1993-98	3.910"			LA-55	4.097"	L-55	4.160"	6-1/16"
327	1965-71	4"			LA-40	4-3/16"	L-40	4-1/4"	6"
350	1968-71	3.800"			LA-25	3.987"	L-25	4.050"	6-7/8"
360, 5.9 L	1971-91	4.080"			LA-705	4-9/32"	L-705	4-11/32"	7"
360, 5.9 L	1997-98	4"			LA-40A	4-3/16"	L-40A	4-1/4"	6-1/4"
401	1974-78	4.165"			LA-80	4-3/8"	L-80	4-7/16"	6-3/4"

CUT TO LENGTH SLEEVES AMERICAN CARS

L.A. SLEEVE

Engine Model	Year	Cyl. Bore	1/16" Wall		3/32" Wall		1/8" Wall		Sleeve Length
			Part No.	O.D.	Part No.	O.D.	Part No.	O.D.	
LINCOLN									
149	1983-85	3.150"	T-254	3.275"	LA-254	3.337"	L-254	3.339"	6-1/2"
232, 3.8 L	1982-00	3-13/16"			LA-43	4"	L-43	4-1/16"	6-5/8"
302, 5.0 L	1973-00	4"			LA-40B	4-3/16"	L-40B	4-1/4"	5-1/8"
317	1952-65	3.800"			LA-25	3.987"	L-25	4.050"	6-7/8"
341	1955	3-15/16"			LA-46	4-1/8"	L-46	4-3/16"	6-7/8"
351, 5.8 L	1969-91	4"			LA-41	4-3/16"	L-41	4-1/4"	6-5/8"
351, 5.8 L	1970-74	4"			LA-40	4-3/16"	L-40	4-1/4"	6"
351, 5.8 L	1975-79	4"			LA-40A	4-3/16"	L-40A	4-1/4"	6-1/4"
368	1956-57	4"			LA-49	4-3/16"	L-49	4-1/4"	6-7/8"
400, 6.6 L	1971-79	4"			LA-41	4-3/16"	L-41	4-1/4"	6-5/8"
430	1958-68	4.300"			LA-54	4.487"	L-54	4.550"	7-9/16"
460	1968-78	4.362"			LA-73	4-35/64"	L-73	4-39/64"	6-7/8"
462	1966-69	4-3/8"			LA-66	4-9/16"	L-66	4-5/8"	6-7/8"
MERCURY									
81, 1.3 L	1988-90	2.795"	T-291A	2.920"	LA-291A	2.982"	L-291A	3.045"	6"
97.6	1981	3.150"	T-89	3-9/32"	LA-89	3-11/32"	L-89	3-13/32"	6"
97.6, 1.6 L	1981-85	3.150"	T-254	3.275"	LA-254	3.337"	L-254	3.399"	6-1/2"
98, 1.6 L	1971-73	3.189"	T-603C	3-5/16"	LA-603C	3-3/8"	L-603C	3-7/16"	5-15/16"
98, 1.6 L	1987-94	3.070"	T-602	3-3/16"	LA-602	3-1/4"	L-602	3-5/16"	6-1/2"
110, 1.8 L	1991-96	3.267"	T-259	3.383"	LA-259	3.456"	L-259	3.518"	7-1/4"
112, 1.8 L	1991	3.287"	T-260	3.407"	LA-260	3.468"	L-260	3.530"	6-1/2"
116, 1.9 L	1985-96	3.228"			LA-002	3.415"	L-002	3.478"	6"
120, 2.0 L	1984-85	3.390"	T-59A	3.525"	LA-59A	3.587"	L-59A	3.650"	6"
122, 2.0 L	1971-74	3.575"			LA-21A	3-3/4"	L-21A	3-13/16"	6"
122, 2.0 L	1984-88	3.386"	T-286	3.516"	LA-286	3.578"	L-286	3.641"	5-1/4"
122, 2.0 L	1993-95	3.267"	T-288	3.392"	LA-288	3.454"	L-288	3.517"	6-1/2"
133, 2.2 L	1988-93	3.386"	T-286	3.516"	LA-286	3.578"	L-286	3.641"	5-1/4"
140, 2.3 L	1974-89	3.781"	T-28A	3.906"	LA-28A	3.968"	L-28A	4-1/32"	6"
140, 2.3 L	1984-94	3.687"			LA-37	3-7/8"	L-37	3-15/16"	6-5/8"
142, 2.3 L	1990-95	3.708"			LA-37D	3.887"	L-37D	3.950"	6-3/8"
144	1960-64	3-1/2"	T-20A	3-5/8"	LA-20A	3-11/16"	L-20A	3-3/4"	5-5/16"
153, 2.5 L	1986-87	3.680"	T-37	3-13/16"	LA-37	3-7/8"	L-37	3-15/16"	6-5/8"
153, 2.5 L	1986-90	3.661"			LA-85	2.847"	L-85	3.910"	6-1/2"
153, 2.5 L	1993-95	3.330"	T-270	3.471"	LA-270	3.533"	L-270	3.596"	6-3/16"
154, 2.5 L	1990-91	3.687"			LA-37	3-7/8"	L-37	3-15/16"	6-5/8"
170	1961-72	3-1/2"	T-20A	3-5/8"	LA-20A	3-11/16"	L-20A	3-3/4"	5-5/16"
171, 2.8 L	1974-79	3.660"			LA-85	3.847"	L-85	3.910"	6-1/2"
177, 2.9 L	1986-90	3.661"			LA-85	2.847"	L-85	3.910"	6-1/2"
182, 3.0 L	1986-05	3-1/2"			LA-20	3-11/16"	L-20	3-3/4"	6"
183, 3.0 L	1993-98	3.425"	T-265C	3-9/16"	LA-265C	3-5/8"	L-265C	3-11/16"	6.150"
195, 3.2 L	1993-95	3.620"			LA-24	3-13/16"	L-24	3-7/8"	6"
200, 3.3 L	1963-83	3-11/16"			LA-37A	3-7/8"	L-37A	3-15/16"	5-1/8"
207, 3.4 L	1996	3.246"	T-34A	3-3/8"	LA-34A	3-7/16"	L-34A	3-1/2"	6-1/2"
215	1952-53	3.567"	T-608A	3-11/16"	LA-608A	3-3/4"	L-608A	3-13/16"	7-1/4"
221	1962-63	3-1/2"	T-708A	3-5/8"	LA-708A	3-11/16"	L-708A	3-3/4"	5-1/2"
223	1954-64	3-5/8"			LA-23	3-13/16"	L-23	3-7/8"	6-11/16"
232, 3.8 L	1982-00	3-13/16"			LA-43	4"	L-43	4-1/16"	6-5/8"

Engine Model	Year	Cyl. Bore	1/16" Wall		3/32" Wall		1/8" Wall		Sleeve Length
			Part No.	O.D.	Part No.	O.D.	Part No.	O.D.	
MERCURY (Cont.)									
239	1939-53	3-3/16"	T-603	3-5/16"	LA-603	3-3/8"	L-603	3-7/16"	6-1/2"
244, 4.0 L	1997-05	3.952"			LA-46	4-1/8"	L-46	4-3/16"	6-7/8"
250, 4.1 L	1969-83	3.687"			LA-37	3-7/8"	L-37	3-15/16"	6-5/8"
255	1949-53	3-3/16"	T-603	3-5/16"	LA-603	3-3/8"	L-603	3-7/16"	6-1/2"
255, 4.2 L	1980-82	3.687"			LA-37A	3-7/8"	L-37A	3-15/16"	5-1/8"
256	1954	3-5/8"			LA-24	3-13/16"	L-24	3-7/8"	6"
260	1962-71	3.800"			LA-25B	3.987"	L-25B	4.050"	5-1/8"
272	1955-58	3-5/8"			LA-24	3-13/16"	L-24	3-7/8"	6"
281, 4.6 L	1991-05	3.551"			LA-273	3.730"	L-273	3.793"	6-1/2"
289	1963-68	4"			LA-40B	4-3/16"	L-40B	4-1/4"	5-1/8"
292	1955-64	3-3/4"			LA-39A	3-15/16"	L-39A	4"	6"
4605cc, 4.6 L	1996	3.543"	T-273	3.688"	LA-273	3.730"	L-273	3.793"	6-1/2"
302, 5.0 L	1973-00	4"			LA-40B	4-3/16"	L-40B	4-1/4"	5-1/8"
312	1956-63	3.800"			LA-25A	3.987"	L-25A	4.050"	6-1/16"
330, 5.4 L	1997-05	3.551"			LA-372	3.740"	L-372	3.802"	6-1/2"
332	1958-59	4"			LA-40A	4-3/16"	L-40A	4-1/4"	6-1/4"
341	1955	3-15/16"			LA-46	4-1/8"	L-46	4-3/16"	6-7/8"
351, 5.8 L	1969-91	4"			LA-41	4-3/16"	L-41	4-1/4"	6-5/8"
351, 5.8 L	1970-74	4"			LA-40	4-3/16"	L-40	4-1/4"	6"
351, 5.8 L	1975-79	4"			LA-40A	4-3/16"	L-40A	4-1/4"	6-1/4"
352	1958-66	4"			LA-40A	4-3/16"	L-40A	4-1/4"	6-1/4"
383	1958-60	4.300"			LA-54	4.487"	L-54	4.550"	7-9/16"
390	1961-71	4.040"			LA-60	4-15/64"	L-60	4-19/64"	6-3/8"
400, 6.6 L	1971-79	4"			LA-41	4-3/16"	L-41	4-1/4"	6-5/8"
406	1963-70	4-1/8"			LA-52C	4-5/16"	L-52C	4-3/8"	7-1/2"
410	1961-71	4.040"			LA-60	4-15/64"	L-60	4-19/64"	6-3/8"
427, 7.0L	1963-78	4-15/64"			LA-22	4-27/64"	L-22	4-31/64"	6-1/4"
428	1963-71	4-1/8"			LA-51	4-5/16"	L-51	4-3/8"	6-15/16"
429	1969-78	4-23/64"			LA-73	4-35/64"	L-73	4-39/64"	6-7/8"
430	1958-60	4.300"			LA-54	4.487"	L-54	4.550"	7-9/16"
460	1968-78	4-23/64"			LA-73	4-35/64"	L-73	4-39/64"	6-7/8"
OLDSMOBILE									
112, 1.8 L	1982	3-1/2"	T-20	3-5/8"	LA-20	3-11/16"	L-20	3-3/4"	6"
112, 1.8 L	1982-86	3.340"	T-270	3.471"	LA-270	3.553"	L-270	3.596"	6-3/16"
121, 2.0 L	1983-89	3-1/2"	T-20	3-5/8"	LA-20	3-11/16"	L-20	3-3/4"	6"
133, 2.2 L	1993-96	3-1/2"			LA-708	3-11/16"	L-708	3-3/4"	6-3/4"
138, 2.3 L	1987-95	3.622"			LA-23	3-13/16"	L-23	3-7/8"	6-11/16"
140	1976-77	3-1/2"	T-20	3-5/8"	LA-20	3-11/16"	L-20	3-3/4"	6"
151, 2.5 L	1977-95	4"			LA-40	4-3/16"	L-40	4-1/4"	6"
173, 2.8 L	1980-90	3-1/2"	T-20A	3-5/8"	LA-20A	3-11/16"	L-20A	3-3/4"	5-5/16"
181, 3.0 L	1982-88	3.800"			LA-25A	3.987"	L-25A	4.050"	6"
191, 3.1 L	1989-99	3-1/2"	T-20	3-5/8"	LA-20	3-11/16"	L-20	3-3/4"	6"
196	1978-79	3-1/2"	T-20	3-5/8"	LA-20	3-11/16"	L-20	3-3/4"	6"
204, 3.3 L	1989-93	3.700"			LA-37D	3.887"	L-37D	3.950"	6-3/8"
207, 3.4 L	1992-05	3.620"			LA-24	3-13/16"	L-24	3-7/8"	6"
225, 3.7 L	1964-67	3-3/4"			LA-39A	3-15/16"	L-39A	4"	6"
231, 3.8 L	1976-05	3.800"			LA-25A	3.987"	L-25A	4.050"	6"

CUT TO LENGTH SLEEVES AMERICAN CARS

L.A. SLEEVE

Engine Model	Year	Cyl. Bore	1/16" Wall		3/32" Wall		1/8" Wall		Sleeve Length
			Part No.	O.D.	Part No.	O.D.	Part No.	O.D.	
OLDSMOBILE (Cont.)									
250	1966-76	3-7/8"			LA-69	4-1/16"	L-69	4-1/8"	6-3/8"
250, 4.1 L	1982-85	3.465"	T-272	3.590"	LA-272	3.642"	L-272	3.715"	6"
252, 4.1 L	1981-84	3.968"			LA-86	4-5/32"	L-86	4-7/32"	6-3/8"
260, 4.3 L	1975-83	3-1/2"	T-20	3-5/8"	LA-20	3-11/16"	L-20	3-3/4"	6"
262	1976-82	3.671"			LA-88	3-55/64"	L-88	3-59/64"	5-1/2"
262, 4.3 L	1982-85	4.057"			LA-50	4-1/4"	L-50	4-5/16"	6-1/4"
262, 4.3 L	1991-05	4"			LA-40	4-3/16"	L-40	4-1/4"	6"
267 4.4 L	1981-82	3-1/2"	T-20	3-5/8"	LA-20	3-11/16"	L-20	3-3/4"	6"
301, 5.0 L	1977-81	4"			LA-40	4-3/16"	L-40	4-1/4"	6"
303	1949-53	3-3/4"			LA-39	3-15/16"	L-39	4"	6-7/16"
305, 5.0 L	1977-93	3.736"			LA-87	3-59/64"	L-87	3-63/64"	6-3/8"
307, 5.0 L	1980-90	3.800"			LA-25A	3.987"	L-25A	4.050"	6"
324	1954-56	3-7/8"			LA-69	4-1/16"	L-69	4-1/8"	6-3/8"
330	1964-67	3-15/16"			LA-47	4-1/8"	L-47	4-3/16"	6-1/4"
350	1976	3.800"			LA-25A	3.987"	L-25A	4.050"	6"
350, 5.7 L	1977-91	4"			LA-40A	4-3/16"	L-40A	4-1/4"	6-1/4"
350, 5.7 L	1968-85	4.057"			LA-50	4-1/4"	L-50	4-5/16"	6-1/4"
371	1957-67	4"			LA-41	4-3/16"	L-41	4-1/4"	6-5/8"
394	1959-64	4-1/8"			LA-52A	4-5/16"	L-52A	4-3/8"	6-1/2"
400	1957-67	4"			LA-41	4-3/16"	L-41	4-1/4"	6-5/8"
403, 6.6 L	1977-81	4.351"			LA-73	4-35/64"	L-73	4-39/64"	6-7/8"
425, 7.0 L	1965-67	4-1/8"			LA-67	4-5/16"	L-67	4-3/8"	7-3/4"
455	1959-76	4-1/8"			LA-52A	4-5/16"	L-52A	4-3/8"	6-3/4"
PACKARD									
245	1938-49	3-1/2"	T-608	3-5/8"	LA-608	3-11/16"	L-608	3-3/4"	7-1/8"
288	1948-54	3-1/2"	T-608	3-5/8"	LA-608	3-11/16"	L-608	3-3/4"	7-1/8"
327	1948-54	3-1/2"	T-608	3-5/8"	LA-608	3-11/16"	L-608	3-3/4"	7-1/8"
356	1940-50	3-1/2"	T-608	3-5/8"	LA-608	3-11/16"	L-608	3-3/4"	7-1/8"
PLYMOUTH									
86, 1.4 L	1980-85	2.913"	T-245	3.038"	LA-245	3.100"	L-245	3.163"	6-1/2"
86, 1.4 L	1981-82	3.028"	T-860	3-5/32"	LA-860	3-7/32"	L-860	3-9/32"	6-1/8"
90, 1.5 L	1985-96	2.968"	T-248	3.093"	LA-248	3.156"	L-248	3.218"	6-1/2"
97, 1.6 L	1982-86	3.175"	T-603	3-5/16"	LA-603	3-3/8"	L-603	3-7/16"	6-1/2"
98, 1.6 L	1973-82	3.028"	T-860	3-5/32"	LA-860	3-7/32"	L-860	3-9/32"	6-1/8"
105, 1.7 L	1978-83	3.130"	T-706A	3-1/4"	LA-706A	3-5/16"	L-706A	3-3/8"	6-7/8"
105, 1.7 L	1985-87	3.188"	T-603	3-5/16"	LA-603	3-3/8"	L-603	3-7/16"	6-1/2"
107, 1.8 L	1989-94	3.173"	T-361	3.295"	LA-361	3.357"	L-361	3.420"	6-1/2"
112, 1.8 L	1991-97	3.188"	T-603	3-5/16"	LA-603	3-3/8"	L-603	3-7/16"	6-1/2"
122, 2.0 L	1983-98	3.346"	T-270	3.471"	LA-270	3.533"	L-270	3.596"	6-3/16"
135, 2.2 L	1981-95	3.445"			LA-38	3-5/8"	L-38	3-11/16"	6"
144, 2.4 L	1992-96	3.406"	T-59	3.525"	LA-59	3.587"	L-59	3.650"	7"
153, 2.5 L	1986-95	3.445"	T-38	3-9/16"	LA-38	3-5/8"	L-38	3-11/16"	6"
156, 2.6 L	1978-89	3.590"			LA-005	3.769"	L-005	3.832"	6-1/4"
170	1960-71	3.400"			LA-59A	3.587"	L-59A	3.650"	6"
181, 3.0 L	1986-00	3.586"			LA-005	3.769"	L-005	3.832"	6-1/4"
183, 3.0 L	1991-96	3.586"			LA-005	3.769"	L-005	3.832"	6-1/4"
198	1970-74	3.400"	T-59	3.525"	LA-59	3.587"	L-59	3.650"	7"
201	1933-41	3-1/8"			LA-604	3-5/16"	L-604	3-3/8"	8-1/8"

Engine Model	Year	Cyl. Bore	1/16" Wall		3/32" Wall		1/8" Wall		Sleeve Length
			Part No.	O.D.	Part No.	O.D.	Part No.	O.D.	
PLYMOUTH (Cont.)									
201, 3.3 L	1990-00	3.661"	T-353	3.786"	LA-353	3.848"	L-353	3.911"	6-1/2"
218	1934-54	3-1/4"	T-605	3-3/8"	LA-605	3-7/16"	L-605	3-1/2"	8-1/8"
225, 3.7 L	1960-87	3.400"	T-59	3.525"	LA-59	3.587"	L-59	3.650"	7"
230	1946-60	3-1/4"			LA-605	3-7/16"	L-605	3-1/2"	8-1/8"
231, 3.8 L	1991-00	3.779"			LA-28A	3.968"	L-28A	4-1/32"	6"
238, 3.9 L	1986-00	3.910"			LA-55	4.097"	L-55	4.160"	6-1/16"
241	1938-41	3-3/8"	T-70D	3-1/2"	LA-70D	3-9/16"	L-70D	3-5/8"	6-1/2"
241	1953-55	3-7/16"			LA-38	3-5/8"	L-38	3-11/16"	6"
242, 4.0 L	1987-92	3-7/8"			LA-78	4-1/16"	L-78	4-1/8"	6-1/2"
259	1955	3-9/16"			LA-21A	3-3/4"	L-21A	3-13/16"	6"
273	1964-69	3-5/8"			LA-24	3-13/16"	L-24	3-7/8"	6"
277	1956-57	3-3/4"			LA-39A	3-15/16"	L-39A	4"	6"
301	1957	3.910"			LA-55	4.097"	L-55	4.160"	6-1/16"
303	1956-57	3-13/16"			LA-43	4"	L-43	4-1/16"	6-5/8"
318, 5.2 L	1957-00	3.910"			LA-55	4.097"	L-55	4.160"	6-1/16"
326	1959	3.950"			LA-006	3.137"	L-006	4.200"	6-7/8"
340	1968-73	4.04"			LA-60	4-15/64"	L-60	4-19/64"	6-3/8"
350	1958	4-1/16"			LA-50	4-1/4"	L-50	4-5/16"	6-1/4"
360, 5.9 L	1971-00	4"			LA-40A	4-3/16"	L-40A	4-1/4"	6-1/4"
361	1958-66	4-1/8"			LA-51	4-5/16"	L-51	4-3/8"	6-5/16"
383	1959-71	4-1/4"			LA-53	4-7/16"	L-53	4-1/2"	6-5/8"
400, 6.6 L	1972-78	4.342"			LA-83	4.530"	L-83	4.592"	6-1/4"
413	1959-69	4-3/16"			LA-57	4-3/8"	L-57	4-7/16"	7"
426	1951-71	4-1/4"			LA-53B	4-7/16"	L-53B	4-1/2"	6-7/8"
440, 7.2 L	1966-78	4.320"			LA-65	4-1/2"	L-65	4-9/16"	6-3/4"
PONTIAC									
61, 1.0 L	1987-88	2.913"	T-245	3.038"	LA-245	3.100"	L-245	3.163"	6-1/2"
97, 1.6 L	1981-87	3.228"			LA-002	3.415"	L-002	3.478"	6"
98, 1.6 L	1990-05	3.110"	T-253	3.235"	LA-253	3.298"	L-253	3.360"	6"
110, 1.8 L	1981-84	3.310"	T-607C	3-7/16"	LA-607C	3-1/2"	L-607C	3-9/16"	6-5/8"
112, 1.8 L	1982	3-1/2"	T-20	3-5/8"	LA-20	3-11/16"	L-20	3-3/4"	6"
112, 1.8 L	1982-86	3.340"	T-270	3.471"	LA-270	3.533"	L-270	3.596"	6-3/16"
121, 2.0 L	1982-86	3-1/2"	T-20	3-5/8"	LA-20	3-11/16"	L-20	3-3/4"	6"
121, 2.0 L	1991-95	3.385"	T-70D	3-1/2"	LA-70D	3-9/16"	L-70D	3-5/8"	6-1/2"
122, 2.0 L	1987-91	3-3/8"	T-70D	3-1/2"	LA-70D	3-9/16"	L-70D	3-5/8"	6-1/2"
133, 2.2 L	1995-97	3-1/2"			LA-708	3-11/16"	L-708	3-3/4"	6-3/4"
134, 2.2 L	1998-00	3-1/2"			LA-708	3-11/16"	L-708	3-3/4"	6-3/4"
138, 2.3 L	1987-95	3.622"			LA-24	3-13/16"	L-24	3-7/8"	6"
140	1976-77	3-1/2"	T-20	3-5/8"	LA-20	3-11/16"	L-20	3-3/4"	6"
151, 2.5 L	1977-93	4"			LA-40	4-3/16"	L-40	4-1/4"	6"
173, 2.8 L	1980-89	3-1/2"	T-20A	3-5/8"	LA-20A	3-11/16"	L-20A	3-3/4"	5-5/16"
181, 3.0 L	1982-88	3.800"			LA-25A	3.987"	L-25A	4.050"	6-1/16"
191, 3.1 L	1988-99	3-1/2"	T-20	3-5/8"	LA-20	3-11/16"	L-20	3-3/4"	6"
195, 3.2 L	1961-63	4-1/16"			LA-50B	4-1/4"	L-50B	4-5/16"	6-3/4"
196	1978-79	3-1/2"	T-20	3-5/8"	LA-20	3-11/16"	L-20	3-3/4"	6"
204, 3.3 L	1989-93	3.700"			LA-37D	3.887"	L-37D	3.950"	6-3/8"
207, 3.4 L	1991-05	3.623"			LA-24	3-13/16"	L-24	3-7/8"	6"

CUT TO LENGTH SLEEVES AMERICAN CARS

L.A. SLEEVE

Engine Model	Year	Cyl. Bore	1/16" Wall		3/32" Wall		1/8" Wall		Sleeve Length	
			Part No.	O.D.	Part No.	O.D.	Part No.	O.D.		
PONTIAC (Cont.)										
215	1961-63	3-1/2"	T-20	3-5/8"	LA-20	3-11/16"	L-20	3-3/4"	6"	
215, 3.5 L	1964-65	3-3/4"			LA-39B	3-15/16"	L-39B	4"	6-1/8"	
229, 3.8 L	1980-84	3.736"			LA-87	3-59/64"	L-87	3-63/64"	6-7/16"	
230	1964-67	3-7/8"			LA-68	4-1/16"	L-68	4-1/8"	6"	
231, 3.8 L	1975-05	3.800"			LA-25A	3.987"	L-25A	4.050"	6-1/16"	
231	1981	4"			LA-40	4-3/16"	L-40	4-1/4"	6"	
239	1941-54	3-9/16"			LA-704	3-3/4"	L-704	3-13/16"	7-1/2"	
248	1934-54	3-1/4"			LA-34	3-7/16"	L-34	3-1/2"	7-1/4"	
250, 4.1 L	1968-76	3-7/8"			LA-69	4-1/16"	L-69	4-1/8"	6-1/2"	
252, 4.1 L	1982-84	3.965"			LA-86	4-5/32"	L-86	4-7/32"	6-3/8"	
260, 4.3 L	1975-76	3-1/2"	T-20	3-5/8"	LA-20	3-11/16"	L-20	3-3/4"	6"	
262, 4.3 L	1982-85	4.058"			LA-50	4-1/4"	L-50	4-5/16"	6-1/4"	
262, 4.3 L	1985-05	4"			LA-40	4-3/16"	L-40	4-1/4"	6"	
265, 4.3 L	1980-81	3-3/4"			LA-39A	3-15/16"	L-39A	4"	6"	
267, 4.4 L	1981	3-1/2"	T-608	3-5/8"	LA-608	3-11/16"	L-608	3-3/4"	7-1/8"	
268	1950-54	3-3/8"			LA-70	3-9/16"	L-70	3-5/8"	7-3/8"	
287	1955	3-3/4"			LA-39	3-15/16"	L-39	4"	6-7/16"	
301, 5.0 L	1977-81	4"			LA-40	4-3/16"	L-40	4-1/4"	6"	
305, 5.0 L	1977-92	3.736"			LA-87	3-59/64"	L-87	3-63/64"	6-3/8"	
307, 5.0 L	1968-72	3-7/8"			LA-68	4-1/16"	L-68	4-1/8"	6"	
307, 5.0 L	1981-90	3.800"			LA-25A	3.987"	L-25A	4.050"	6-1/16"	
316	1956	3-15/16"			LA-46	4-1/8"	L-46	4-3/16"	6-7/8"	
326, 5.3 L	1964-87	3-23/32"			LA-27A	3-29/32"	L-27A	3-31/32"	6-1/4"	
347	1956-67	3-15/16"			LA-47	4-1/8"	L-47	4-3/16"	6-1/4"	
350X, 5.7 L	1974-81	3.800"			LA-25A	3.987"	L-25A	4.050"	6-1/16"	
350P, 5.7 L	1968-78	3-7/8"			LA-69	4-1/16"	L-69	4-1/8"	6-3/8"	
350L, 5.7 L	1977-97	4"			LA-40	4-3/16"	L-40	4-1/4"	6"	
350, 5.7 L	1978-85	4.057"			LA-50	4-1/4"	L-50	4-5/16"	6-1/4"	
389, 6.4 L	1958-67	4-1/16"			LA-50	4-1/4"	L-50	4-5/16"	6-1/4"	
400, 6.6 L	1967-79	4-1/8"			LA-52A	4-5/16"	L-52A	4-3/8"	6-5/8"	
403, 6.6 L	1977-81	4.351"			LA-73	4-35/64"	L-73	4-39/64"	6-7/8"	
421	1963-67	4-3/32"			LA-61	4-9/32"	L-61	4-11/32"	6-3/8"	
428	1967-69	4-1/8"			LA-51	4-5/16"	L-51	4-3/8"	6-5/16"	
455, 7.5 L	1968-76	4.152"			LA-79	4.337"	L-79	4.400"	6-1/4"	
SATURN										
116, 1.9 L	1990-96	3.228"			LA-002	3.415"	L-002	3.478"	6"	
1.9 L	1999	3.228"	Flanged Replacement Sleeve Part No. FL-3218							5.400"
STUDEBAKER										
169, 170, 186	1939-63	3"			LA-31	3-3/16"	L-31	3-1/4"	6-3/8"	
194, 3.2 L	1965-66	3-9/16"	T-21A	3-11/16"	LA-21A	3-3/4"	L-21A	3-3/16"	6"	
233	1951-64	3-3/8"			LA-71	3-9/16"	L-71	3-5/8"	6"	
226, 246	1938-60	3-5/16"			LA-607	3-1/2"	L-607	3-9/16"	7-9/16"	
259	1955-64	3-9/16"			LA-21	3-3/4"	L-21	3-13/16"	6-11/16"	
283, 4.6 L	1965	3-7/8"			LA-69	4-1/16"	L-69	4-1/8"	6-3/8"	
352	1956	4"			LA-49	4-3/16"	L-49	4-1/14"	6-7/8"	

DISP.	ENGINE MODEL	YEAR	CYLINDER BORE		1/16" Wall		3/32" Wall		1/8" Wall		Sleeve Length
			MM	INCHES	PART NO.	O.D.	PART NO.	O.D.	PART NO.	O.D.	
ACURA											
97CID	D16A1 1.6 L	86-89	75mm	2.952"	T-276	3.077"	LA-276	3.140"	L-276	3.202"	6-1/2"
1.6 L	D16		74mm	2.913"	Flanged Ductile Iron Performance Sleeve Part No. FL-3216					5.275"	
163CID	C27A1 2.7 L	87-90	87mm	3.425"	T-265C	3-9/16"	LA-265C	3-5/8"	L-265C	3-11/16"	6.150"
1678cc	B17A1 1.7 L	92-95	80.98mm	3.188"	T-603A	3-5/16"	LA-603A	3-3/8"	L-603A	3-7/16"	6"
1834cc	B18A1 1.8 L	91-95	80.98mm	3.188"	T-603	3-5/16"	LA-603	3-3/8"	L-603	3-7/16"	6-1/2"
2156cc	F22B1	1997	85mm		T-292	3.471"	LA-292	3.533"	L-292	3.596"	6-1/4"
2451cc	G25A1 2.5 L	92-95	85mm	3.346"	T-292	3.471"	LA-292	3.533"	L-292	3.596"	6-1/2"
2977cc	C30A1 3.0 L	91-95	90mm	3.543"	T-273	3.668"	LA-273	3.730"	L-273	3.793"	6-1/2"
3206cc	C32A1 3.2 L	91-96	90mm	3.543"	T-273	3.668"	LA-273	3.730"	L-273	3.793"	6-1/2"
	1.6, 1.7, 1.8 L		80mm	3.150"	Flanged Ductile Iron Sleeve Part No. FL-3186					5-1/2"	
ALFA ROMEO											
	1300		74mm	2.913"	Replacement Sleeve Part No. FL-3184					5.465"	
	1750		80mm	3.150"	Replacement Sleeve Part No. FL-3132					6"	
	2600		83mm	3.228"	Replacement Sleeve Part No. FL-3115					5.940"	
	2000		84mm	3.267"	Replacement Sleeve Part No. FL-3114					5.990"	
AUDI											
1296cc	80, 80L	72-on	75mm	2.952"	T-276	3.077"	LA-276	3.140"	L-276	3.202"	6-1/2"
1471cc	Foxx 1.5 L	73-76	76.5mm	3.011"	T-277	3-1/8"	LA-277	3-3/16"	L-277	3-1/4"	6-1/2"
1588cc	Foxx, LGL 1.6 L	75-81	79.6mm	3.136"	T-278	3-1/4"	LA-278	3-5/16"	L-278	3-3/8"	6-1/2"
1588cc	1.6 L	81-87	76.5mm	3.0122"	T-277	3-1/8"	LA-277	3-3/16"	L-277	3-1/4"	6-1/2"
1715cc	1.7 L	81-84	79.5mm	3.136"	T-278	3-1/4"	LA-278	3-5/16"	L-278	3-3/8"	6-1/2"
1760cc	90, 100LS, 100S	70-72	81.5mm	3.208"	T-279	3.333"	LA-279	3.395"	L-279	3.458"	6-1/2"
1780cc	1.8 L	83-91	81mm	3.189"	T-603	3-5/16"	LA-603	3-3/8"	L-603	3-7/16"	6-1/2"
1871cc	100GL, LS	72-77	84mm	3.307"	T-281	3-7/16"	LA-281	3-1/2"	L-281	3-9/16"	6-1/2"
1986cc	2.0 L	79-83	76.5mm	3.012"	T-277	3-1/8"	LA-277	3-3/16"	L-277	3-1/4"	6-1/2"
2144cc	2.1 L	83-84	79.5mm	3.136"	T-278	3-1/4"	LA-278	3-5/16"	L-278	3-3/8"	6-1/2"
2226cc	2.2 L	85-88	79.5mm	3.136"	T-278	3-1/4"	LA-278	3-5/16"	L-278	3-3/8"	6-1/2"
2226cc	MC,AAN 2.2 L	91-95	81mm	3.189"	T-603	3-5/16"	LA-603	3-3/8"	L-603	3-7/16"	6-1/2"
2309cc	2.3 L	87-92	82.5mm	3.248"	T-34A	3.373"	LA-34A	3.438"	L-34A	3.498"	6-1/2"
2771cc	100CS	93	82mm	3.228"	T-002	3.353"	LA-002	3.415"	L-002	3.478"	6"
2771cc	AAH 2.8 L	92-95	82.5mm	3.248"	T-34A	3.373"	LA-34A	3.438"	L-34A	3.498"	6-1/2"
3562cc	PT 3.6 L	91	81mm	3.188"	T-603	3-5/16"	LA-603	3-3/8"	L-603	3-7/16"	6-1/2"
4172cc	ABH 4.2 L	92-95	84.5mm	3.332"	T-270C	3.457"	LA-270C	3.522"	L-270C	3.582"	6-3/16"
ASTON MARTIN											
	DB2 Wet Liner	1957	83mm	3.267"	Flanged Replacement Sleeve Part No. FL-3203					6.410"	
AUSTIN											
848cc	850 Mini	60-67	62.91mm	2.477"	T-230	2.606"	LA-230	2.665"	L-230	2.727"	5.156"
948cc	A35, A40	62-65	62.92mm	2.477"	T-230	2.606"	LA-230	2.665"	L-230	2.727"	5.156"
998cc	Mini Cooper	64-67	64.6mm	2.542"	T-232	2.667"	LA-232	2.729"	L-232	2.792"	5.280"
1098cc	A40 MK II	62-65	64.6mm	2.542"	T-232	2.667"	LA-232	2.729"	L-232	2.792"	5.280"
1275cc	Mini Cooper	63-69	70.61mm	2.780"	T-243	2.905"	LA-243	2.967"	L-243	3.030"	5-9/16"
1489cc	A50, A55	54-61	73mm	2.875"	T-214A	3"	LA-214A	3-1/16"	L-214A	3-1/8"	6"
1798cc	Marina GT	73-76	80.25mm	3.159"	T-280	3.275"	LA-280	3.337"	L-280	3.399"	6-1/16"

CUT TO LENGTH SLEEVES FOREIGN CARS



DISP.	ENGINE MODEL	YEAR	CYLINDER BORE		1/16" Wall		3/32" Wall		1/8" Wall		Sleeve Length
			MM	INCHES	PART NO.	O.D.	PART NO.	O.D.	PART NO.	O.D.	
AUSTIN HEALEY											
948cc	Sprite MK II	57-67	62.91mm	2.477"	T-230	2.606"	LA-230	2.665"	L-230	2.727"	5.156"
1098cc	MK II, III	63-66	64.6mm	2.542"	T-232	2.667"	LA-232	2.729"	L-232	2.792"	5.280"
1275cc	MK IV	67-70	70.6mm	2.780"	T-243	2.905"	LA-243	2.967"	L-243	3.030"	5-9/16"
2639cc	100/6	56-59	79.4mm	3-1/8"	T-706A	3-1/4"	LA-706A	3-5/16"	L-706A	3-3/8"	6-7/8"
2912cc	3000 MK, I, II, III	59-68	83.3mm	3.282"	T-260	3.407"	LA-260	3.468"	L-260	3.530"	6-1/2"
2660cc	100/4	53-56	87.3mm	3-7/16"	T-38	3-9/16"	LA-38	3-5/8"	L-38	3-11/16"	6"
BMW											
1573cc	1600, ENG 114	64-71	84mm	3.307"	T-281	3-7/16"	LA-281	3-1/2"	L-281	3-9/16"	6-1/2"
1773cc	1800, ENG 118	64-68	84mm	3.307"	T-281	3-7/16"	LA-281	3-1/2"	L-281	3-9/16"	6-1/2"
1796cc	M42B18 1.8 L	91-95	84mm	3.312"	T-281	3-7/16"	LA-281	3-1/2"	L-281	3-9/16"	6-1/2"
1990cc	2000, 2002 ENG 121, 2	66-76	89mm	3.503"	T-20	3-5/8"	LA-20	3-11/16"	L-20	3-3/4"	6"
2302cc	S14B23 2.3 L	91	93.70mm	3.687"	T-37	3-13/16"	LA-37	3-7/8"	L-37	3-15/16"	6-5/8"
2494cc	M20B25 2.5 L	91-95	84mm	3.312"	T-281	3-7/16"	LA-281	3-1/2"	L-281	3-9/16"	6-1/2"
2494cc	525i, 2.5L, 6 cyl.	93	84mm	3.307"	T-281	3-7/16"	LA-281	3-1/2"	L-281	3-9/16"	6-1/2"
2494cc	2500	69-71	86mm	3.385"	T-70D	3-1/2"	LA-70D	3-9/16"	L-70D	3-5/8"	6-1/2"
2788c	2800, ENG 128	69-70	86mm	3.385"	T-70D	3-1/2"	LA-70D	3-9/16"	L-70D	3-5/8"	6-1/2"
2985cc	3.0 SI, 530 I, 630 CSI	75	89mm	3.503"	T-708	3-5/8"	LA-708	3-11/16"	L-708	3-3/4"	6-3/4"
3205cc	7331	78 on	89mm	3.503"	T-708	3-5/8"	LA-708	3-11/16"	L-708	3-3/4"	6-3/4"
2990cc	25OUSB30 3.0 L	96	86mm	3.385"	T-70D	3-1/2"	LA-70D	3-9/16"	L-70D	3-5/8"	6-1/2"
3152cc	M3 3.2 L	97	86.4mm	3.400"	T-59A	3.525"	LA-59A	3.587"	L-59A	3.650"	6"
3430cc	M30B35 3.5 L	91-95	92mm	3.622"	T-24	3-3/4"	LA-24	3-13/16"	L-24	3-7/8"	6"
3535cc	S38B36 3.6 L	91-95	93.70mm	3.687"	T-37	3-13/16"	LA-37	3-7/8"	L-37	3-15/16"	6-5/8"
3982cc	M60B40 4.0 L	96	89mm	3.500"	T-20	3-5/8"	LA-20	3-11/16"	L-20	3-3/4"	6"
4988cc	M70B50 5.0 L	91-95	84mm	3.312"	T-281	3-7/16"	LA-281	3-1/2"	L-281	3-9/16"	6-1/2"
CHEVROLET LUV - SPRINT											
1817cc	Luv	72-81	84mm	3.307"	T-281	3-7/16"	LA-281	3-1/2"	L-281	3-9/16"	6-1/2"
61 CID	Sprint 1.0 L	85-88	74mm	2.913"	T-245	3.038"	LA-245	3.100"	L-245	3.163"	6-1/2"
CHRYSLER, DODGE											
1468cc	4G15(A) 1.5 L	91-95	75.387mm	2.968"	T-248	3.093"	LA-248	3.156"	L-248	3.218"	6-1/2"
1498cc	Cricket	71-73	86.1mm	3.391"	T-286	3.516"	LA-286	3.578"	L-286	3.641"	5.260"
1715cc	Omni-Horizon 1.7 L	78-83	79.5mm	3.130"	T-278	3-1/4"	LA-278	3-5/16"	L-278	3-3/8"	6-1/2"
1597cc	1600 Colt, Arrow, 1.6 L	71-87	77mm	3.031"	T-860	3-5/32"	LA-860	3-7/32"	L-860	3-9/32"	6-1/8"
1834cc	4G93(D)	92-95	80.98mm	3.188"	T-603	3-5/16"	LA-603	3-3/8"	L-603	3-7/16"	6-1/2"
1995cc	2000 Colt, Arrow	75-78	84mm	3.307"	T-281	3-7/16"	LA-281	3-1/2"	L-860	3-9/16"	6-1/8"
1997cc	G6313(v) 2.0 L	91	85mm	3.346"	T-292	3.471"	LA-292	3.533"	L-292	3.596"	6-1/2"
2350cc	4G64(w) 2.4 L	92-95	86.5mm	3.405"	T-59	3.525"	LA-59	3.587"	L-59	3.650"	7"
2555cc	FW Engs., Colt 2.6 L	78-84	91.1mm	3.587"	T-005	3.712"	LA-005	3.769"	L-005	3.832"	6-1/4"
DAEWOO											
98 CID	LANOS 1.6L	99-02	79mm	3.110"	T-253	3.235"	LA-253	3.298"	L-253	3.360"	6"

DISP.	ENGINE MODEL	YEAR	CYLINDER BORE		1/16" Wall		3/32" Wall		1/8" Wall		Sleeve Length
			MM	INCHES	PART NO.	O.D.	PART NO.	O.D.	PART NO.	O.D.	
DATSUN, NISSAN											
1237cc	A-12,A-12A 1.2 L	78-82	75mm	2.952"	T-276	3.077"	LA-276	3.140"	L-276	3.202"	6-1/2"
1270cc	E13,L-4 1.3 L	81-89	76mm	2.992"	T-31	3-1/8"	LA-31	3-3/16"	L-31	3-1/4"	6-3/8"
1288cc	1-13,L-4 1.3 L	58-75	73mm	2.874"	T-214B	3"	LA-214B	3-1/16"	L-214B	3-1/8"	6-1/2"
1299cc	J-13, 1.3 L	61-74	73mm	2-7/8"	T-214B	3"	LA-214B	3-1/16"	L-214B	3-1/8"	6-1/2"
1397cc	A-14, 1.4 L	75-82	76mm	2.992"	T-31	3-1/8"	LA-31	3-3/16"	L-31	3-1/4"	6-3/8"
1483cc	J15	71-89	78mm	3.071"	T-602	3-3/16"	LA-602	3-1/4"	L-602	3-5/16"	6-1/2"
1488cc	210,310,A-15,1.5 L	80-87	76mm	2.992"	T-31	3-1/8"	LA-31	3-3/16"	L-31	3-1/4"	6-3/8"
1595cc	L-16 1.5 L	68-73	83mm	3.267"	T-288	3.392"	LA-288	3.454"	L-288	3.517"	6-1/2"
1597cc	CA16D, E	87	78mm	3.071"	T-602	3-3/16"	LA-602	3-1/4"	L-602	3-5/16"	6-1/2"
1597cc	1.6 L	93	76mm	2.992"	T-31	3-1/8"	LA-31	3-3/16"	L-31	3-1/4"	6-3/8"
1597cc	GA16DE 1.6 L	82-99	76mm	2.992"	T-31	3-1/8"	LA-31	3-3/16"	L-31	3-1/4"	6-3/8"
1680cc	CD17	82-86	80mm	3.150"	T-254	3.275"	LA-54	3.337"	L-254	3.399"	6-1/2"
1770cc	L-18	73-75	85mm	3.346"	T-292	3.471"	LA-292	3.533"	L-292	3.596"	6-1/2"
1952cc	L-20B, 2.0 L	74-80	85mm	3.346"	T-292	3.471"	LA-292	3.533"	L-292	3.596"	6-1/2"
1974cc	CA20S,C20E 2.0 L	82-89	84.5mm	3.326"	T-270C	3.457"	LA-270C	3.522"	L-270C	3.582"	6-3/16"
1982cc	U20	67-70	83mm	3.267"	T-259	3.383"	LA-259	3.456"	L-259	3.518"	7-1/4"
1998cc	SR20DE 2.0 L	91-99	86mm	3.391"	T-286	3.516"	LA-286	3.578"	L-286	3.641"	5.260"
2000cc	SRL-311	67-70	87.2mm	3.435"	T-38	3-9/16"	LA-38	3-5/8"	L-38	3-11/16"	6"
2187cc	200SX,Z22E, 2.2 L	80-83	87mm	3.425"	T-265C	3-9/16"	LA-265C	3-5/8"	L-265C	3-11/16"	6.150"
2389cc	KA24DE	89-00	89mm	3.503"	T-608	3-5/8"	LA-608	3-11/16"	L-608	3-3/4"	7-1/8"
2389cc	Z24	83-90	89mm	3.503"	T-608	3-5/8"	LA-608	3-11/16"	L-608	3-3/4"	7-1/8"
2393cc	L-24, 810, 2.4 L	78-84	83mm	3.267"	T-288	3.392"	LA-288	3.454"	L-288	3.517"	6-1/2"
2398cc	KA-24E 2.4 L	85-95	89mm	3.504"	T-20	3-5/8"	LA-20	3-11/16"	L-20	3-3/4"	6"
2400cc	L-26	78-80	83mm	3.267"	T-288	3.392"	LA-288	3.454"	L-288	3.517"	6-1/2"
2488cc	SD-25 2.5 L	83-88	89mm	3.504"	T-20	3-5/8"	LA-20	3-11/16"	L-20	3-3/4"	6"
2565cc	L-26	74-75	83mm	3.267"	T-288	3.392"	LA-288	3.454"	L-288	3.517"	6-1/2"
2753cc	I-28, 280Z, 2.8 L	75-83	86mm	3.385"	T-70D	3-1/2"	LA-70D	3-9/16"	L-70D	3-5/8"	6-1/2"
	SD-22 Diesel	81-82	83mm	3.267"	Replacement Sleeve Part No. FL-3131					6.930"	
2960cc	VG30DE 3.0 L	89-98	87mm	3.437"	T-38	3-9/16"	LA-38	3-5/8"	L-38	3-11/16"	6"
2988cc	VQ30DE 3.0 L	96	93mm	3.661"	T-353	3.786"	LA-353	3.848"	L-353	3.911"	6-1/2"
FERRARI											
	212 V-12		68mm	2.677"	Replacement Sleeve Part No. FL-3110						
	206 GT Dino		86mm	3.385"	Replacement Sleeve Part No. FL-3139						
	250 GT 128B	1956	73mm	2.874"	Replacement Sleeve Part No. FL-3171					4.170"	
	250 GT 128F	1961	73mm	2.874"	Replacement Sleeve Part No. FL-3170					4.018"	
	250 GT A57 Tour de France	1973	73mm	2.874"	Replacement Sleeve Part No. FL-3220					4.035"	
	275 GTB V-12		77mm	3.031"	Replacement Sleeve Part No. FL-3111					4.015"	
	308 GTB		81mm	3.188"	Replacement Sleeve Part No. FL-3108						
	308 2 Valve Carb	75-79	82mm	3.228"	Replacement Sleeve Part No. FL-3178					4.765"	
2927cc	308 4 Valve V-8, 328 GTB, GTS V-8		81mm	3.188"	Replacement Sleeve Part No. FL-3140 (original sleeve is aluminum)					4.764"	
	330 GTC V-12		77mm	3.031"	Replacement Sleeve Part No. FL-3109 O.D. 3.231					4.671"	
	330 GT V-12		77mm	3.031"	Replacement Sleeve Part No. FL-3130 O.D. 3.271					4.767"	
	360 V-8 Modena	2001	85mm	3.346"	Replacement Sleeve Part No. FL-3190					4.845"	
	365 GTB4		81mm	3.188"	Replacement Sleeve Part No. FL-3112					4.770"	

All Ferrari Sleeve Deck Height Lengths are +.010 Custom Sleeves Allow 6 Weeks Delivery

CUT TO LENGTH SLEEVES FOREIGN CARS



DISP.	ENGINE MODEL	YEAR	CYLINDER BORE		1/16" Wall		3/32" Wall		1/8" Wall		Sleeve Length
			MM	INCHES	PART NO.	O.D.	PART NO.	O.D.	PART NO.	O.D.	
FIAT											
633cc	600 Berlina	55-61	60mm	2.362"	T-228	2.478"	LA-228	2.549"	L-228	2.612"	4.527"
767cc	600D	61-66	62mm	2.440"	T-207F	2-9/16"	LA-207F	2-5/8"	L-207F	2-11/16"	4.330"
817cc	850	68-69	64mm	2.519"	T-296	2.644"	LA-296	2.706"	L-296	2.769"	6-1/2"
843cc	850	65-68	65mm	2.559"	T-209F	2-11/16"	LA-209F	2-3/4"	L-209F	2-13/16"	4.409"
903cc	850	70-73	65mm	2.559"	T-209F	2-11/16"	LA-209F	2-3/4"	L-209F	2-13/16"	4.409"
1089cc	1100, 1100R	57-62	68mm	2.677"	T-238F	2-11/16"	LA-238F	2-7/8"	L-238F	2-15/16"	5.826"
1116cc	128	72-73	80mm	3.150"	T-298	3.275"	LA-298	3.337"	L-298	3.399"	5-15/16"
1197cc	124	66-69	73mm	2-7/8"	T-214F	3"	LA-214F	3-1/16"	L-214F	3-1/8"	5.520"
1221cc	1100D, 1200	62-66	72mm	2.834"	T-56F	2.959"	LA-56F	3.022"	L-56F	3.085"	5.826"
1290cc	128, 128SL	73-75	86mm	3.385"	T-70D	3-1/2"	LA-70D	3-9/16"	L-70D	3-5/8"	6-1/2"
1608cc	124, 124B	71-73	80mm	3.150"	T-254F	3.275"	LA-254F	3.337"	L-254F	3.399"	5-5/8"
1756cc	124, 131	74-78	84mm	3.307"	T-281F	3-7/16"	LA-281F	3-1/2"	L-281F	3-9/16"	5-5/8"
FORD COURIER											
1599cc	Fiesta	78	80.98mm	3.188"	T-603C	3-5/16"	LA-603C	3-3/8"	L-603F	3-7/16"	5-5/16"
1796cc		72-78	78mm	3.070"	T-602	3-3/16"	LA-602	3-1/4"	L-602	3-5/16"	6-1/2"
1970cc	Courier 2.0 L	79-82	80mm	3.150"	T-254	3.275"	LA-254	3.337"	L-254	3.399"	6-1/2"
2791cc	2800	79	93mm	3.661"	T-353	3.786"	LA-353	3.848"	L-353	3.911"	6-1/2"
80.8cc	Festiva 1.3 L	88-90	71mm	2.793"	T-291A	2.940"	LA-291A	2.982"	L-291A	3.045"	6"
GEO											
993cc	1.0 L	91-95	74mm	2.913"	T-245	3.038"	LA-245	3.100"	L-245	3.163"	6-1/2"
1590cc	1.6 L	91-95	81.5mm	3.208"	T-279	3.333"	LA-279	3.395"	L-279	3.458"	6-1/2"
1590cc	1.6 L	91-95	80mm	3.149"	T-254	3.275"	LA-254	3.337"	L-254	3.399"	6-1/2"
1803cc	1.8 L	92-95	80mm	3.149"	T-254	3.275"	LA-254	3.337"	L-254	3.399"	6-1/2"
	97/1.6 L	89-95	75mm	2.958"	T-247A	3.077"	LA-247A	3.140"	L-247A	3.202"	6-1/4"
	97/1.6 L	89-90	80.98mm	3.188"	T-603	3-5/16"	LA-603	3-3/8"	L-603	3-7/16"	6-1/2"
	97/1.6 L	90-93	80mm	3.149"	T-254	3.275"	LA-254	3.337"	L-254	3.399"	6-1/2"
HILMAN											
	Minx MK IV to VII	50-59	65mm	2-9/16"	T-209	2-11/16"	LA-209	2-3/4"	L-209	2-13/16"	6-1/4"
1390cc	Minx MK VIII	55-56	76.2mm	3"	T-31C	3-1/8"	LA-31C	3-3/16"	L-31C	3-1/4"	6"
1494cc	Minx Series III, IIIA	59-61	78.99mm	3.110"	T-253	3.235"	LA-253	3.298"	L-253	3.360"	6"
1592cc	Minx 1600	61-65	81.5mm	3.210"	T-256	3.335"	LA-256	3.401"	L-256	3.464"	6"
1600cc	Avenger		87mm	3-7/16"	T-703	3-9/16"	LA-703	3-5/8"	L-703	3-11/16"	7-1/2"
1725cc	Minx GT	66-70	81.5mm	3.210"	T-256	3.335"	LA-256	3.401"	L-256	3.464"	6"
HONDA											
1200cc	Civic	73	70mm	2.755"	T-212C	2-7/8"	LA-212C	2-15/16"	L-212C	3"	7"
1238cc	Civic EB, 1.2 L	74-79	72mm	2.834"	T-56	2.959"	LA-56	3.022"	L-56	3.085"	6-1/4"
1335cc	Civic DX, EJ1	80-83	72mm	2.834"	T-56	2.959"	LA-56	3.022"	L-56	3.085"	6-1/4"
1488cc	CVCC, 1.5 L	75-87	74mm	2.913"	T-245	3.038"	LA-245	3.100"	L-245	3.163"	6-1/2"
1493cc	D15B1,B2,B6 1.5 L	88-95	75mm	2.952"	T-247A	3.077"	LA-247A	3.140"	L-247A	3.202"	6-1/4"
1500cc	Civic CVCC, 1.5 L	75-80	74mm	2.913"	T-245	3.038"	LA-245	3.100"	L-245	3.163"	6-1/2"
1590cc	D16A6 Civic Delsolisi, 1.6 L	92-00	75mm	2.952"	T-247A	3.077"	LA-247A	3.140"	L-247A	3.202"	6-1/4"
1600cc	Accord, 1.6 L	77-78	74mm	2.913"	T-245	3.038"	LA-245	3.100"	L-245	3.163"	6-1/2"
	D16 1.6 L		74mm	2.913"	Flanged Ductile Iron Performance Sleeve Part No. FL-3216					5.275"	
1751cc	Accord, 1.8 L	79-83	77mm	3.031"	T-860	3-5/32"	LA-860	3-7/32"	L-860	3-9/32"	6-1/8"
1829cc	A18, ES1, ET2	83-87	80mm	3.150"	T-298	3.275"	LA-298	3.337"	L-298	3.399"	5-13/16"
1955cc	A20, BS1	85-89	87.2mm	3.256"	T-34	3-3/8"	LA-34	3-7/16"	L-34	3-1/2"	7-1/4"
1958cc	B20, F20A5 2.0 L	88-91	81mm	3.188"	T-603	3-5/16"	LA-603	3-3/8"	L-603	3-7/16"	6-1/2"

DISP.	ENGINE MODEL	YEAR	CYLINDER BORE		1/16" Wall		3/32" Wall		1/8" Wall		Sleeve Length
			MM	INCHES	PART NO.	O.D.	PART NO.	O.D.	PART NO.	O.D.	
HONDA (Cont.)											
2056cc	B21A1 2.1 L	90-91	83mm	3.267"	T-288	3.392"	LA-288	3.454"	L-288	3.517"	6-1/2"
2156cc	F22A1,A4,A6 2.2 L	90-97	85mm	3.346"	T-292	3.471"	LA-292	3.533"	L-292	3.596"	6-1/2"
2156cc	H22A1 2.2 L	96	87mm	3.437"	T-38	3-9/16"	LA-38	3-5/8"	L-38	3-11/16"	6"
2259cc	H23A1 2.3 L	92-95	87mm	3.437"	T-38	3-9/16"	LA-38	3-5/8"	L-38	3-11/16"	6"
	1.6, 1.7, 1.8 L		80mm	3.150"	Flanged Ductile Iron Sleeve Part No. FL-3186/FL-3186A						5-1/2"
HYUNDAI											
1468cc	1.5 L	86-95	75.5mm	2.972"	T-248	3.093"	LA-248	3.156"	L-248	3.218"	6-1/2"
1596cc	1.6 L	92-95	82.5mm	3.248"	T-34A	3.373"	LA-34A	3.438"	L-34A	3.498"	6-1/2"
1597cc	1.6 L	85-90	76.9mm	3.027"	T-860	3-5/32"	LA-860	3-7/32"	L-860	3-9/32"	6-1/8"
1836cc	1.8 L	93-95	80.5mm	3.169"	T-361	3.295"	LA-361	3.357"	L-361	3.420"	6-1/2"
1997cc	2.0 L	92-95	85mm	3.346"	T-292	3.471"	LA-292	3.533"	L-292	3.596"	6-1/2"
2351cc	2.4 L	88-91	86.5mm	3.405"	T-59	3.525"	LA-59	3.587"	L-59	3.650"	7"
2972cc	3.0 L	89-95	91.1mm	3.586"	T-005	3.712"	LA-005	3.769"	L-005	3.832"	6-1/4"
INFINITI											
1998cc	SR20DE(C) 2.0 L	91-99	86mm	3.385"	T-70D	3-1/2"	LA-70D	3-9/16"	L-70D	3-5/8"	6-1/2"
2960cc	VG30DE(A,H) 3.0 L	91-95	87mm	3.437"	T-38	3-9/16"	LA-38	3-5/8"	L-38	3-11/16"	6"
4494cc	VH45DE(N) 4.5 L	91-95	93mm	3.661"	T-353	3.786"	LA-353	3.848"	L-353	3.911"	6-1/2"
ISUZU											
1471cc	4XC1	85-89	77mm	3.031"	T-860	3-5/32"	LA-860	3-7/32"	L-860	3-9/32"	6-1/8"
1588cc	4XE1-WT-V 1.6 L	86-93	80mm	3.149"	T-254	3.275"	LA-254	3.337"	L-254	3.399"	6-1/2"
1809cc	4XE1-W 1.8 L	92	80mm	3.149"	T-254	3.275"	LA-254	3.337"	L-254	3.399"	6-1/2"
1817cc	G-180, Z 1.8 L	81-85	84mm	3.307"	T-281	3-7/16"	LA-281	3-1/2"	L-281	3-9/16"	6-1/2"
1949cc	G-2009, Z 1.9 L	83-87	87mm	3.425"	T-265C	3-9/16"	LA-265C	3-5/8"	L-265C	3-11/16"	6.150"
1994cc	4ZC-1 4.2 L	85-89	88mm	3.465"	T-272V	3.590"	LA-272V	3.642"	L-272V	3.715"	6-1/2"
2254cc	4ZD1 2.3 L	86-95	89mm	3.503"	T-20	3-5/8"	LA-20	3-11/16"	L-20	3-3/4"	6"
2259cc	4ZE1 2.6 L	88-90	92.5mm	3.642"	T-861	3.771"	LA-861	3.833"	L-861	3.895"	6-1/2"
	353, 5.7L		102mm	4.016"	T-40A	4-1/8"	LA-40A	4-3/16"	L-40A	4-1/4"	6-1/4"
2259cc	Trooper II, 2.6 L	88-92	92.6mm	3.646"	T-861	3.771"	LA-861	3.833"	L-861	3.895"	6-1/2"
2827cc	LL2	88-92	89mm	3.503"	T-20A	3-5/8"	LA-20A	3-11/16"	L-20A	3-3/4"	5-5/16"
3137cc	CPC	91-94	89mm	3.503"	T-20A	3-5/8"	LA-20A	3-11/16"	L-20A	3-3/4"	5-5/16"
4300cc	W, X	96-00	101.6mm	4"			LA-40	4-3/16"	L-40	4-1/4"	6"
JAGUAR											
2483cc	XK120,140,150 MK,I,II	56-68	83mm	3.268"	T-259	3.383"	LA-259	3.456"	L-259	3.518"	7-1/4"
3781cc	MK II,3.8 MK, IX, XKE	59-64	87mm	3.425"	T-265	3-9/16"	LA-265	3-5/8"	L-265	3-11/16"	7-1/8"
4235cc	4.2L, MK X&E, XJ6	64-76	92mm	3.622"	T-268	3.765"	LA-268	3.817"	L-268	3.880"	7"
JENSEN-HEALEY (LOTUS)											
	903		94mm	3.700"	Flanged Replacement Sleeve Part No. FL-3128						5.375"
LAMBORGHINI											
	4.0L V-12		82mm	3.228"	Flanged Replacement Sleeve Part No. FL-3183						4.252"
	5.0L		85.5mm	3.366"	Flanged Replacement Sleeve Part No. FL-3151						4.365"
LEXUS											
2508cc	2VZ-FE 2.5 L	91	87mm	3.437"	T-38	3-9/16"	LA-38	3-5/8"	L-38	3-11/16"	6"
2959cc	3VZ-FE 3.0 L	92-95	87mm	3.437"	T-38	3-9/16"	LA-38	3-5/8"	L-38	3-11/16"	6"
2997cc	2JZ-GE 3.0 L	92-95	86mm	3.391"	T-286A	3.516"	LA-286A	3.578"	L-286A	3.641"	6"
3969cc	1VZ-FE 4.0 L	91-95	87mm	3.437"	T-38	3-9/16"	LA-38	3-5/8"	L-38	3-11/16"	6"
3969cc	2.6 L	94-96	87.6mm	3.457"	T-272	3.582"	LA-272	3.647"	L-272	3.707"	6"

CUT TO LENGTH SLEEVES FOREIGN CARS



DISP.	ENGINE MODEL	YEAR	CYLINDER BORE		1/16" Wall		3/32" Wall		1/8" Wall		Sleeve Length
			MM	INCHES	PART NO.	O.D.	PART NO.	O.D.	PART NO.	O.D.	
MASERRATI											
	V-6, 2.7 L	71-72	87mm	3.425"	Flanged Replacement Sleeve Part No. FL-3102						5.060"
	V-6 3L End Sleeve	73-81	91.6mm	3.609"	Flanged Replacement Sleeve Part No. FL-3100E						5.060"
	V-6 3L Center Sleeve	73-81	91.6mm	3.609"	Flanged Replacement Sleeve Part No. FL-3101C						5.060"
	3.5L In-Line 6 cyl.		88mm	3.464"	Flanged Replacement Sleeve Part No. FL-3192E End Sleeve						6.062"
	3.5L In-Line 6 cyl.		88mm	3.464"	Flanged Replacement Sleeve Part No. FL-3192C Center Sleeve						6.062"
	3.7L In-Line 6 cyl.		86mm	3.385"	Flanged Replacement Sleeve Part No. FL-3105						6.195"
	4.0L In-Line 6 cyl.		88mm	3.464"	Flanged Replacement Sleeve Part No. FL-3106						6.350"
	4.0L V-8		88mm	3.464"	Flanged Replacement Sleeve Part No. FL-3134						
	4.2L V-8 End Sleeve		94mm	3.700"	Flanged Replacement Sleeve Part No. FL-3104E						5.625"
	4.2L V-8 Center Sleeve		94mm	3.700"	Flanged Replacement Sleeve Part No. FL-3104C						5.625"
	4.3L V-8	2002	92mm	3.622"	Flanged Replacement Sleeve Part No. FL-3191						6.062"
	4.7L V-8		88mm	3.464"	Flanged Replacement Sleeve Part No. FL-3107						5.535"
MAZDA											
1000cc		68-74	68mm	2.677"	T-238M	2-13/16"	LA-238M	2-15/16"	L-238M	2-15/16"	6-1/2"
1169cc	1200	70-72	70mm	2.755"	T-212M	2-7/8"	LA-212M	2-15/16"	L-212M	3"	6-1/2"
1272cc	Mizer, GLC, TC 1.3L	76-79	73mm	2.874"	T-214B	3"	LA-214B	3-1/16"	L-214B	3-1/8"	6-1/2"
1490cc	GLC, ES 1.5 L	79-85	77mm	3.031"	T-860	3-5/32"	LA-860	3-7/32"	L-860	3-9/32"	6-1/8"
1586cc	616,B-1600,808,1.6L	70-78	78mm	3.070"	T-602	3-3/16"	LA-602	3-1/4"	L-602	3-5/16"	6-1/2"
1597cc	BE6 1.6L	86-95	78mm	3.071"	T-602	3-3/16"	LA-602	3-1/4"	L-602	3-5/16"	6-1/2"
1597cc	MX-3, 1.6L	93	78mm	3.070"	T-602	3-3/16"	LA-602	3-1/4"	L-602	3-5/16"	6-1/2"
1769cc	LA2V,3V,SV2A CB1V929, 1.8 L		80mm	3.150"	T-254	3.275"	LA-254	3.337"	L-254	3.399"	6-1/2"
1796cc	VB, 618, 1800, 1.8L	70-78	78mm	3.070"	T-602	3-3/16"	LA-602	3-1/4"	L-602	3-5/16"	6-1/2"
1970cc	626 MA, 2.0 L	78-84	80mm	3.150"	T-254	3.275"	LA-254	3.337"	L-254	3.399"	6-1/2"
180/3.0L	929 MPV	88-91	90mm	3.543"	T-273	3.668"	LA-273	3.730"	L-273	3.793"	6-1/2"
1839cc	BPE-D 1.8L	90-00	83mm	3.268"	T-288	3.392"	LA-288	3.454"	L-288	3.517"	6-1/2"
1844cc	K8D 1.8L	92-95	74.689mm	2.940"	T-215T	3-1/16"	LA-215T	3-1/8"	L-215T	3-3/16"	5-3/4"
1991cc	FS 2.0L	93-95	83mm	3.268"	T-288	3.392"	LA-288	3.454"	L-288	3.517"	6-1/2"
1998cc	B2000,626 2.0L	83-87	86mm	3.385"	T-70D	3-1/2"	LA-70D	3-9/16"	L-70D	3-5/8"	6-1/2"
2184cc	F2,L4 2.2L	87-93	86mm	3.385"	T-70D	3-1/2"	LA-70D	3-9/16"	L-70D	3-5/8"	6-1/2"
2209cc	B2200 2.2L	82-84	88.9mm	3.500"	T-20	3-5/8"	LA-20	3-11/16"	L-20	3-3/4"	6"
2255cc	KJ 2.3L	96	80.3mm	3.150"	T-298	3.275"	LA-298	3.337"	L-298	3.399"	5-15/16"
2298cc	A	94	96mm	3.780"	T-28A	3.906"	LA-28A	3.968"	L-28A	4-1/32"	6"
2496cc	KL 2.5L	93-95	84.5mm	3.331"	T-008	3.456"	LA-008	3.520"	L-008	3.580"	6"
2954cc	JE 3.0L	91-95	90mm	3.543"	T-273	3.668"	LA-273	3.730"	L-273	3.793"	6-1/2"
2954cc	U	94-97	89mm	3.503"	T-20A	3-5/8"	LA-20A	3-11/16"	L-20A	3-3/4"	5-5/16"
3996cc		91-92	100.4mm	3.953"	T-006	4.078"	LA-006	4.143"	L-006	4.203"	6-9/16"
4016cc	X	91-00	100.4mm	3.952"			LA-006	3.137"	L-006	4.200"	6-7/8"
MERCEDES											
1767cc	170D, 180D, OM636	49-61	75mm	2.952"	Flanged Replacement Sleeve Part No. FL-006						
1767cc	170D, 180D, OM636	49-61	75mm	2.952"			LA-247	3.140"	L-247	3.202"	7-1/2"
1897cc	190, 190D	51-61	85mm	3.346"	Flanged Replacement Sleeve Part No. FL-007						
1897cc	190, 190D	51-61	85mm	3.346"			LA-270	3.533"	L-270	3.596"	6.160"
1897cc	180D, 190D, 200D, OM621	62-67	87mm	3.425"	Flanged Replacement Sleeve Part No. FL-004						6.230"

DISP.	ENGINE MODEL	YEAR	CYLINDER BORE		1/16" Wall		3/32" Wall		1/8" Wall		Sleeve Length
			MM	INCHES	PART NO.	O.D.	PART NO.	O.D.	PART NO.	O.D.	
MERCEDES (Cont.)											
1897cc	180D, 190D, 200D, OM621	62-67	87mm	3.425"			LA-265C	3-5/8"	L-265C	3-11/16"	6.150"
2197cc	220,M115,220D, OM615	68-73	87mm	3.425"	T-265	3-9/16"	LA-265	3-5/8"	L-265	3-11/16"	7-1/8"
2298cc	2.3L	91-92	95.5mm	3.763"	T-39D	3.888"	LA-39D	3.953"	L-39D	4.013"	6-7/16"
2307cc	230,Eng. M115	74 on	93.75mm	3.961"	T-37	3-13/16"	LA-37	3-7/8"	L-37	3-15/16"	6-5/8"
2376cc	240D, Eng. OM616	74	91mm	3.582"	Flanged Replacement Sleeve Part No. FL-005					6.230"	
2376cc	240D, Eng. OM616	74	91mm	3.582"			LA-005	3.769"	L-005	3.832"	6-1/4"
2497cc	2.5L	91-92	87mm	3.425"	T-265	3-9/16"	LA-265	3-5/8"	L-265	3-11/16"	7-1/8"
2597cc	2.6L	91-92	83mm	3.267"	T-259	3.383"	LA-259	3.456"	L-259	3.518"	7-1/4"
2746cc	280,C,CE,S,SE,Eng. OM110	73	86mm	3.385"	T-70	3-1/2"	LA-70	3-9/16"	L-70	3-5/8"	7-3/8"
2778cc	250C,280S,300SEL, Eng. M130	68-72	86.5mm	3.4055"	T-59	3.525"	LA-59	3.587"	L-59	3.650"	7"
2960cc	3.0L	91-95	88.5mm	3.484"	T-362	3.615"	LA-362	3.673"	L-362	3.735"	6-1/2"
3005cc	300D,CD, Eng.OM617	75 on	91mm	3.582"	Flanged Replacement Sleeve Part No. FL-005					6.230"	
3005cc	300D,CD, Eng.OM617	75 on	91mm	3.582"			LA-005	3.769"	L-005	3.832"	6-1/4"
3199cc	3.2L	92	90mm	3.543"	T-273	3.668"	LA-273	3.730"	L-273	3.793"	6-1/2"
3499cc	280E, 300SEL, Eng. M116	70-71	92mm	3.622"	T-23	3-3/4"	LA-23	3-13/16"	L-23	3-7/8"	6-11/16"
3499cc	3.5 L	91-92	89mm	3.500"	T-708	3-5/8"	LA-708	3-11/16"	L-708	3-3/4"	6-3/4"
4196cc	4.2 L	91-95	83mm	3.267"	T-259	3.383"	LA-259	3.456"	L-259	3.518"	7-1/4"
4520cc	280SE,300SEL,450SE	72-73	92mm	3.622"	T-23	3-3/4"	LA-23	3-13/16"	L-23	3-7/8"	6-11/16"
4972cc	5.0 L	91-95		3.800"			LA-25A	3.987"	L-25A	4.050"	6"
5547cc	5.6 L	91		3.800"			LA-25	3.987"	L-25	4.050"	6-7/8"
5987cc	6.0 L	92	89mm	3.500"	T-708	3-5/8"	LA-708	3-11/16"	L-708	3-3/4"	6-3/4"
6329cc	300SEL,600,Eng.M100	65-72	103mm	4.055"			LA-60	4-15/64"	L-60	4-19/64"	6-3/8"
	500 GAS		96mm	3.799"	Flanged Replacement Sleeve Part No. FL-3113					6.060"	
MG											
948cc	Midget MK I	61-62	62.9mm	2.4775"	T-230	2.606"	LA-230	2.665"	L-230	2.727"	5.156"
1098cc	100, MK I, II, III	62-67	64.576mm	2.542"	T-232	2.667"	LA-232	2.729"	L-232	2.792"	5.280"
1250cc	TD, TC, TF	39-58	66.5mm	2.618"	T-29	2-3/4"	LA-29	2-13/16"	L-29	2-7/8"	6-1/4"
1275cc	MK III	67-74	70.612mm	2.780"	T-243G	2.905"	LA-243G	2.967"	L-243G	3.030"	6-1/2"
1466cc	TF-1500	54-55	72mm	2.834"	T-56	2.959"	LA-56	3.022"	L-56	3.085"	6-1/4"
1489cc	MGA, Magnette	59-62	73.025mm	2-7/8"	T-214B	3"	LA-214B	3-1/16"	L-214B	3-1/8"	6-1/2"
1493cc	MK IV	75-79	73.647mm	2.899"	T-275	3.025"	LA-275	3.087"	L-275	3.150"	6-1/4"
1588cc	MGA MK I	59-61	75.387mm	2.968"	T-248	3.093"	LA-248	3.156"	L-248	3.218"	6-1/2"
1622cc	Magnette MK IV, MGA, MK II	61	76.187mm	2.999"	T-31	3-1/8"	LA-31	3-3/16"	L-31	3-1/4"	6-3/8"
1798cc	MGB, GT	62-79	80.251mm	3.159"	T-255	3.275"	LA-255	3.337"	L-255	3.399"	6-1/4"
2912cc	MGC, MGC/CT	68-69	83.325mm	3.280"	T-260	3.407"	LA-260	3.468"	L-260	3.530"	6-1/2"
MITSUBISHI											
1088cc	KE44,L4 1.1 L	67-70	73mm	2.874"	T-214B	3"	LA-214B	3-1/16"	L-214B	3-1/8"	6-1/2"
1238cc	4G36,L4 1.2 L	75-78	73mm	2.874"	T-214B	3"	LA-214B	3-1/16"	L-214B	3-1/8"	6-1/2"
1289cc	4G30,L4 1.3 L	69-71	73mm	2.874"	T-214B	3"	LA-214B	3-1/16"	L-214B	3-1/8"	6-1/2"
1410cc	L4 1.4 L	78-83	74mm	2.913"	T-245	3.038"	LA-245	3.100"	L-245	3.163"	6-1/2"
1439cc	4G33,L4 1.4 L	74-88	73mm	2.874"	T-214B	3"	LA-214B	3-1/16"	L-214B	3-1/8"	6-1/2"
1468cc	4G15, 1.5L	90-96	75.387mm	2.968"	T-248	3.093"	LA-248	3.156"	L-248	3.218"	6-1/2"
1597cc	G32B, 1.6L	71-89	76.9mm	3.028"	T-860	3-5/32"	LA-860	3-7/32"	L-860	3-9/32"	6-1/8"
1597cc	4G61, 1.6L	91-92	82.25mm	3.240"	T-34A	3-3/8"	LA-34A	3-7/16"	L-34A	3-1/2"	6-1/2"

CUT TO LENGTH SLEEVES FOREIGN CARS



DISP.	ENGINE MODEL	YEAR	CYLINDER BORE		1/16" Wall		3/32" Wall		1/8" Wall		Sleeve Length
			MM	INCHES	PART NO.	O.D.	PART NO.	O.D.	PART NO.	O.D.	
MITSUBISHI (Cont.)											
1755cc	4G37, 1.8L	90-95	80.6mm	3.173"	T-361	3.295"	LA-361	3.357"	L-361	3.420"	6-1/2"
1795cc	G62B, 1.8L	83-88	80.6mm	3.173"	T-361	3.295"	LA-361	3.357"	L-361	3.420"	6-1/2"
1995cc	2.0L	74-88	84mm	3.307"	T-281	3-7/16"	LA-281	3-1/2"	L-281	3-9/16"	6-1/2"
1997cc	4G63, 2.0L	83-95	85mm	3.346"	T-292	3.471"	LA-292	3.533"	L-292	3.596"	6-1/2"
2351cc	4G64, 2.4L	83-97	86.5mm	3.405"	T-59	3.525"	LA-59	3.587"	L-59	3.650"	7"
2555cc	G-54B, 2.6L	78-92	91.1mm	3.582"	T-005	3.712"	LA-005	3.796"	L-005	3.832"	6-1/4"
2972cc	4G72, 3.0L	78-97	91.1mm	3.586"	T-005	3.712"	LA-005	3.769"	L-005	3.832"	6-1/4"
OPEL											
993cc	Kadette	62-65	72mm	2.834"	T-56	2.959"	LA-56	3.022"	L-56	3.085"	6-1/4"
1078cc	Kadette, GT 1100	66-71	75mm	2.952"	T-247A	3.077"	LA-247A	3.140"	L-247A	3.202"	6-1/4"
1492cc	Kadette	67-68	82.5mm	3.248"	T-002	3.353"	LA-002	3.415"	L-002	3.478"	6"
1817cc		76 on	84mm	3.307"	T-607	3-7/16"	LA-607	3-1/2"	L-607	3-9/16"	7-1/2"
1897cc	GT 1900	70-75	93mm	3.661"	T-359	3.786"	LA-359	3.848"	L-359	3.911"	7"
	Rekord 2000	77	86.5mm	3.405"	T-59	3.525"	LA-59	3.587"	L-59	3.650"	7"
	Rekord 2100D	72	88mm	3.465"	T-272	3.590"	LA-272	3.642"	L-272	3.715"	6"
2490cc	Commodore B	72	87mm	3.425"	T-265	3-9/16"	LA-265	3-5/8"	L-265	3-11/16"	7-1/8"
PEUGEOT											
1800cc	306		83mm	3.268"	Flanged Replacement Sleeve Part No. FL-3208					5.556"	
PORSCHE											
	944		100mm	3.937"	Flanged Replacement Sleeve Part No. FL-3209					5-3/4"	
	996TT Wet Liner		100mm	3.937"	Flanged Replacement Sleeve Part No. FL-3217					4.725"	
RENAULT											
	R14 4 Cyl Wet		76mm	2.992"	Flanged Replacement Sleeve Part No. FL-3176					5.275"	
SAAB											
1699cc	95, 96 Sonnett III	71-74	90mm	3.543"	T-273	3.668"	LA-273	3.730"	L-273	3.793"	6-1/2"
1709cc	99	69-71	83.487mm	3.286"	T-260	3.407"	LA-260	3.468"	L-260	3.530"	6-1/2"
1854cc	99	72-73	86.987mm	3.427"	T-265	3-9/16"	LA-265	3-5/8"	L-265	3-11/16"	7-1/8"
1985cc	99L, LE, EMs	73-74	90mm	3.543"	T-273	3.668"	LA-273	3.730"	L-273	3.793"	6-1/2"
1985cc	B202L 2.0 L	91-95	90mm	3.543"	T-273	3.668"	LA-273	3.730"	L-273	3.793"	6-1/2"
2119cc	B212i 2.1 L	91-95	93mm	3.661"	T-353	3.786"	LA-353	3.848"	L-353	3.911"	6-1/2"
2290cc	B234i,LPT 2.3 L	91-96	90mm	3.543"	T-273	3.668"	LA-273	3.730"	L-273	3.793"	6-1/2"
SIMCA											
944cc	1000	62-68	68mm	2.677"	T-238	2-13/16"	LA-238	2-7/8"	L-238	2-15/16"	5-1/4"
1118cc		68-70	74mm	2.913"	T-245	3.038"	LA-245	3.100"	L-245	3.163"	6-1/2"
1204cc		69-71	74mm	2.913"	T-245	3.038"	LA-245	3.100"	L-245	3.163"	6-1/2"
1294cc	2R GT1308	71-76	76.7mm	3.020"	T-860	3-5/32"	LA-860	3-7/32"	L-860	3-9/32"	6-1/8"
1475cc	1500	64-70	75mm	2.952"	T-247A	3.077"	LA-247A	3.140"	L-247A	3.202"	6-1/4"
	160GT/180	72	87.7mm	3.435"	T-38	3-9/16"	LA-38	3-5/8"	L-38	3-11/16"	6"
SUBARU											
1088cc	EA 61 1.1L	70-72	76mm	2.992"	T-31	3-1/8"	LA-31	3-3/16"	L-31	3-1/4"	6-3/8"
1189cc	Justy-GL 1.2L	91-93	78mm	3.070"	T-602	3-3/16"	LA-602	3-1/4"	L-602	3-5/16"	6-1/2"
1361cc	1400,DL,GL,GF,4W 1.4L	73-76	85mm	3.346"	T-270	3.471"	LA-270	3.533"	L-270	3.596"	6-3/16"
1595cc	1600 DL,GL4WD 1.6L	76-84	92mm	3.622"	T-23	3-3/4"	LA-23	3-13/16"	L-23	3-7/8"	6-11/16"
1781cc	Brat, EA81, 1.8 L	80-84	92mm	3.622"	T-24	3-3/4"	LA-24	3-13/16"	L-24	3-7/8"	6"
1781cc	XTGL 1.8 L	91-95	92mm	3.624"	T-24	3-3/4"	LA-24	3-13/16"	L-24	3-7/8"	6"
2212cc	Legacy 2.2 L	91-95	96.25mm	3.821"	T-43	3-15/16"	LA-43	4"	L-43	4-1/16"	6-5/8"
2672cc	XT-6 2.7 L	91	92mm	3.624"	T-23	3-3/4"	LA-23	3-13/16"	L-23	3-7/8"	6-11/16"
3318cc	SVX 3.3 L	92-95	96.25mm	3.821"	T-43	3-15/16"	LA-43	4"	L-43	4-1/16"	6-5/8"

DISP.	ENGINE MODEL	YEAR	CYLINDER BORE		1/16" Wall		3/32" Wall		1/8" Wall		Sleeve Length
			MM	INCHES	PART NO.	O.D.	PART NO.	O.D.	PART NO.	O.D.	
SUNBEAM											
1390cc	Rapier Series 1	56-58	76.2mm	3"	T-31	3-1/8"	LA-31	3-3/16"	L-31	3-1/4"	6-3/8"
1494cc	Series I, II, III	58-61	78.99mm	3.110"	T-253	3.235"	LA-253	3.298"	L-253	3.360"	6"
1725cc	Series, IIIA, V, GT	61-70	81.539mm	3.210"	T-256	3.335"	LA-256	3.401"	L-256	3.464"	6"
260CU	Tiger V8	64		3.800"			LA-25A	3.987"	L-25A	4.050"	6"
SUZUKI											
1298cc	1.3 L, G10, G13	85-96	74mm	2.913"	T-245	3.038"	LA-245	3.100"	L-245	3.163"	6-1/2"
97 CID	1.6 L	89-92	75mm	2.952"	T-276	3.077"	LA-276	3.140"	L-276	3.202"	6-1/2"
	I285-4 (LJ20)	1972	61mm	2.401"	Flange Sleeve		FL-3166	2.590"			4.765"
TOYOTA											
1078cc	Corolla 1100, KC Eng	68-70	75mm	2.952"	T-247A	3.077"	LA-247A	3.140"	L-247A	3.202"	6-1/4"
1165cc	Corolla 1200,3KC	71-79	75mm	2.952"	T-247A	3.077"	LA-247A	3.140"	L-247A	3.202"	6-1/4"
1290cc	4KC 1.3 L	81-84	75mm	2.952"	T-247A	3.077"	LA-247A	3.140"	L-247A	3.202"	6-1/4"
1452cc	1AC Tercel	79-88	77.5mm	3.051"	T-602	3-3/16"	LA-602	3-1/4"	L-602	3-5/16"	6-1/2"
1457cc	3 E-E 1.5 L	87-95	73mm	2.875"	T-214A	3"	LA-214A	3-1/16"	L-214A	3-1/8"	6"
1495cc	5 EFE 1.5 L	94-95	74mm	2.913"	T-245	3.038"	LA-245	3.100"	L-245	3.163"	6-1/2"
1497cc	1.3 L, 5 EFE	92-98	74mm	2.913"	T-245	3.038"	LA-245	3.100"	L-245	3.163"	6-1/2"
1587cc	1600 RT81, 12R	71-73	80.5mm	3.169"	T-361	3.295"	LA-361	3.357"	L-361	3.420"	6-1/2"
1587cc	4A-FE-GE 1.6L	83-97	81mm	3.189"	T-603	3-5/16"	LA-603	3-3/8"	L-603	3-7/16"	6-1/2"
1588cc	Corolla 1600, 2TC Eng. 1.6 L	71-79	85mm	3.346"	T-292	3.471"	LA-292	3.533"	L-292	3.596"	6-1/2"
1626cc	1Y, L4 1.0 L	83-88	86mm	3.385"	T-70D	3-1/2"	LA-70D	3-9/16"	L-70D	3-5/8"	6-1/2"
1762cc	7A-FE 1.8L	93-97	81mm	3.189"	T-603	3-5/16"	LA-603	3-3/8"	L-603	3-7/16"	6-1/2"
1770cc	Corolla 1.8 L	79-82	85mm	3.346"	T-292	3.471"	LA-292	3.533"	L-292	3.596"	6-1/2"
1808cc	16R,J,B,U 1.8 L	73-79	88.5mm	3.484"	T-362	3.615"	LA-362	3.673"	L-362	3.735"	6-1/2"
1812cc	2Y, L4 2.0 L	83-88	86mm	3.385"	T-70D	3-1/2"	LA-70D	3-9/16"	L-70D	3-5/8"	6-1/2"
1839cc	Diesel 1.8 L	84-88	83mm	3.268"	T-259	3.383"	LA-259	3.456"	L-259	3.518"	7-1/4"
1858cc	Corona MK II, 8RC	70-74	86mm	3.385"	T-70D	3-1/2"	LA-70D	3-9/16"	L-70D	3-5/8"	6-1/2"
1897cc	Crown, 3RB, 3RC	63-70	88mm	3.464"	T-272	3.590"	LA-272	3.642"	L-272	3.715"	6"
1968cc	Celica, Corona 18RC	72-75	88.5mm	3.484"	T-362	3.615"	LA-362	3.673"	L-362	3.735"	6-1/2"
1972cc	2IR, L-4	70-78	84mm	3.307"	T-281	3-7/16"	LA-281	3-1/2"	L-281	3-9/16"	6-1/2"
1994cc	5R	67-78	88mm	3.464"	T-272	3.590"	LA-272	3.642"	L-272	3.715"	6"
1995cc	2SELC	83-86	84mm	3.307"	T-281F	3-7/16"	LA-281F	3-1/2"	L-281F	3-9/16"	5-5/8"
1998cc	3YEC,38FE 2.0 L	84-00	86mm	3.385"	T-70D	3-1/2"	LA-70D	3-9/16"	L-70D	3-5/8"	6-1/2"
2164cc	5S-FE 2.2 L	91-95	87mm	3.425"	T-265C	3-9/16"	LA-265C	3-5/8"	L-265C	3-11/16"	6.150"
2188cc	L	81-83	92mm	3.622"	T-24	3-3/4"	LA-24	3-3/16"	L-24	3-7/8"	6"
2189cc	Celica, Corona 20R, 2.2 L	75-80	88.5mm	3.484"	T-362	3.615"	LA-362	3.673"	L-362	3.735"	6-1/2"
2237cc	44E,44EC 2.2 L	86-90	91mm	3.582"	T-005	3.712"	LA-005	3.769"	L-005	3.832"	6-1/4"
2253cc	Crown, 2M	67-71	75mm	2.952"	T-247A	3.077"	LA-247A	3.140"	L-247A	3.202"	6-1/4"
2367cc	122R, Celica, Corona 2.4 L	81-95	92mm	3.622"	T-23	3-3/4"	LA-23	3-13/16"	L-23	3-7/8"	6-11/16"
2438cc	Tacoma 2.4 L	96-02	95mm	3.740"			LA-87	3.925"	L-87	3.987"	6-3/8"
2563cc	Corona MKII 4M,2.6L	73-80	80mm	3.149"	T-254	3.275"	LA-254	3.337"	L-254	3.399"	6-1/2"

CUT TO LENGTH SLEEVES FOREIGN CARS



DISP.	ENGINE MODEL	YEAR	CYLINDER BORE		1/16" Wall		3/32" Wall		1/8" Wall		Sleeve Length
			MM	INCHES	PART NO.	O.D.	PART NO.	O.D.	PART NO.	O.D.	
TOYOTA (Cont.)											
2507cc	2VE-FE 2.5 L	89-91	87mm	3.437"	T-38	3-9/16"	LA-38	3-5/8"	L-38	3-11/16"	6"
2759cc	122R Eng., Celica Corona 2.4L	81-88	83mm	3.268"	T-288	3.392"	LA-288	3.454"	L-288	3.517"	6-1/2"
	2.7 L 165 3RZFE T100	94-01	95mm	3.740"			LA-87	3.925"	L-87	3.987"	6-3/8"
2952cc	3VZ-FE 3.0 L	93	87mm	3.437"	T-38	3-9/16"	LA-38	3-5/8"	L-38	3-11/16"	6"
2956cc	7 MGE 3.0 L	86-92	83mm	3.268"	T-288	3.392"	LA-288	3.454"	L-288	3.517"	6-1/2"
2995cc	1 MZ-FE 3.0 L	96	87.3mm	3.437"	T-38	3-9/16"	LA-38	3-5/8"	L-38	3-11/16"	6"
3878cc	Landcruiser, FJ25, FJ40 Eng.	60-74	90mm	3.543"	T-273T	3.668"	LA-273T	3.730"	L-273T	3.793"	7"
	Diesel P.U.	81	90mm	3.543"	Flanged Replacement Sleeve Part No. FL-3129						
4230cc	Landcruiser, 2F Eng.	74-92	94mm	3.700"			LA-37	3-7/8"	L-37	3-15/16"	6-5/8"
180/3.0L	7 MGE	86-91	82.99mm	3.267"	T-288	3.392"	LA-288	3.454"	L-288	3.517"	6-1/2"
2959cc	3VZ-E 3.0 L	86-95	87.5mm	3.445"	T-38	3-9/16"	LA-38	3-5/8"	L-38	3-11/16"	6"
	Sienna 6-Cyl.	98	87.406mm	3.441"	Flanged Replacement Sleeve Part No. FL-3219						5.190"
2977cc	Landcruiser Diesel "B" engine		95mm	3.740"	Flanged Replacement Sleeve Part No. FL-3207						7.480"
TRIUMPH											
948cc	Herald	58-61	63mm	2.480"	T-230	2.606"	LA-230	2.665"	L-230	2.727"	5.156"
1147cc	Spitfire MK II	62-67	69.289mm	2.727"	T-274	2.852"	LA-274	2.915"	L-274	2.978"	5-5/16"
1296cc	Spitfire MK III,IV	67-72	73.647mm	2.899"	T-275	3.025"	LA-275	3.087"	L-275	3.150"	5-5/16"
1493cc	Spitfire MK IV	73-80	73.647mm	2.899"	T-275T	3.025"	LA-275T	3.087"	L-275T	3.150"	6-1/4"
1998cc	GT6, MKI,II,III,2000	66-74	74.689mm	2.940"	T-215T	3-1/16"	LA-215T	3-1/8"	L-215T	3-3/16"	5-3/4"
1998cc	TR-7	75-80	90.287mm	3.554"	T-21A	3-11/16"	LA-21A	3-3/4"	L-21A	3-13/16"	6"
2186cc	TR-2 up to TR4A		87mm	3.428"	Flanged Replacement Sleeve Part No. FL-3136						6.760"
2498cc	TR250, TR6	68-76	74.689mm	2.940"	T-215T	3-1/16"	LA-215T	3-1/8"	L-215T	3-3/16"	5-3/4"
2997cc	Stag	71-73	85.987mm	3.385"	T-70T	3-1/2"	LA-70T	3-9/16"	L-70T	3-5/8"	5-3/4"
VOLKSWAGEN											
1457cc	1.5L	77-92	79.5mm	3.130"	T-706A	3-1/4"	LA-706A	3-5/16"	L-706A	3-3/8"	6-7/8"
1471cc	1.5L	74-80	76.5mm	3.011"	T-277	3-1/8"	LA-277	3-3/16"	L-277	3-1/4"	6-1/2"
1588cc	Rabbit Scirocco 1.6L	76-80	79.5mm	3.130"	T-706A	3-1/4"	LA-706A	3-5/16"	L-706A	3-3/8"	6-7/8"
1588cc	1V 1.6L	81-95	76.5mm	3.011"	T-277	3-1/8"	LA-277	3-3/16"	L-277	3-1/4"	6-1/2"
1715cc	Jetta, Quantum 1.7L	81-83	79.5mm	3.130"	T-706A	3-1/4"	LA-706A	3-5/16"	L-706A	3-3/8"	6-7/8"
	300 Type 1, 111		90mm	3.543"	Chromoloy Alloy Cylinders - 4 Per Set V-3116S						
	300 Type 1, 111		92mm	3.622"	Chromoloy Alloy Cylinders - 4 Per Set V-3117S						
	300 Type 1, 111		94mm	3.700"	Chromoloy Alloy Cylinders - 4 Per Set V-3118S						
1780cc	RV-PF-JH 1.8L	83-95	81mm	3.189"	T-603	3-5/16"	LA-603	3-3/8"	L-603	3-7/16"	6-1/2"
110 cid	1.8L Passat	98-00	82.04mm	3.230"	T-002	3.353"	LA-002	3.415"	L-002	3.478"	6"
1984cc	9A 2.0L	91-94	82.5mm	3.248"	T-34A	3-3/8"	LA-34A	3-7/16"	L-34A	3.-1/2"	6-1/2"
2144cc	2.1L	83-84	79.5mm	3.130"	T-706A	3-1/4"	LA-706A	3-5/16"	L-706A	3-3/8"	6-7/8"
2226cc	2.2L	85-88	79.5mm	3.130"	T-706A	3-1/4"	LA-706A	3-5/16"	L-706A	3-3/8"	6-7/8"
2860cc	AAA 2.8L	92-95	81.5mm	3.208"	T-279	3.333"	LA-279	3.395"	L-279	3.458"	6-1/2"
VOLVO											
2316cc	B-230F 2.3L	91-95	95.25mm	3.781"	T-28A	3.906"	LA-28A	3.968"	L-28A	4.032"	6"
2922cc	B-6304F 2.9L	92-95	83mm	3.267"	T-288	3.392"	LA-288	3.454"	L-288	3.517"	6-1/2"

Engine Model	Year	Cyl. Bore	1/16" Wall		3/32" Wall		1/8" Wall		Sleeve Length
			Part No.	O.D.	Part No.	O.D.	Part No.	O.D.	
BRIGGS & STRATTON									
8B, 82999		2-3/8"	C-32	2-1/2"	CA-32	2-9/16"	CL-32	2-5/8"	4-1/2"
100200, 100900		2-1/2"	C-41B	2-5/8"	CA-41B	2-11/16"	CL-41B	2-3/4"	4-1/2"
92000, 130900		2-9/16"	C-42B	2-11/16"	CA-42B	2-3/4"	CL-42B	2-13/16"	4-3/8"
92000, 130900		2-9/16"	FLC-42B	2-11/16"	Flanged Sleeve				4-3/8"
B, BL, BR, 14FB		2-5/8"	C-45B	2-3/4"	CA-45B	2-13/16"	CL-45B	2-7/8"	4-1/2"
K, R, RG, 140000		2-3/4"	T-177	2-7/8"	LA-177	2-15/16"	L-177	3"	5-7/8"
110908		2.781"	T-243	2.905"	LA-243	2.966"	L-243	3.030"	5-9/16"
23, Z, ZZR6, 191700		3"	T-31	3-1/8"	LA-31	3-3/16"	L-31	3-1/4"	6-3/8"
24D, 243430		3-1/16"	T-602	3-3/16"	LA-602	3-1/4"	L-602	3-5/16"	6-1/2"
30, 300431		3-7/16"	T-38	3-9/16"	LA-38	3-5/8"	L-38	3-11/16"	6"
32, 325430		3-7/16"	T-38	3-9/16"	LA-38	3-5/8"	L-38	3-11/16"	6"
CHRYSLER INDUSTRIAL									
Ind5, 6, 6a, 30, 31, M46, 46S		3-1/4"	T-605	3-3/8"	LA-605	3-7/16"	L-605	3-1/2"	8-1/8"
Ind9, 12, M8, 28, 48		3-1/4"	T-605	3-3/8"	LA-605	3-7/16"	L-605	3-1/2"	8-1/8"
Ind16, 16A, 32, 33		3-7/16"			LA-701	3-5/8"	L-701	3-11/16"	8-1/8"
Ind7, 7A, 8, 8A, M37, 47, 47S		3-7/16"			LA-701	3-5/8"	L-701	3-11/16"	8-1/8"
H318, HT318, M80, 80A		3.910"			LA-55	4.097"	L-55	4.160"	6-1/16"
H170		3.400"	T-59A	3.525"	LA-59A	3.587"	L-59A	3.650"	5-15/16"
H225		3.400"	T-59	3.525"	LA-59	3.587"	L-59	3.650"	7"
HT361		4-1/8"			LA-51	4-5/16"	L-51	4-3/8"	6-5/16"
HB413, HT413		4-3/16"			LA-57	4-3/8"	L-57	4-7/16"	7"
FORD INDUSTRIAL									
172		3.900"			LA-90	4.087"	L-90	4.150"	7"
200		3.680"	T-37	3-13/16"	LA-37	3-7/8"	L-37	3-15/16"	6-5/8"
223		3-5/8"	T-23	3-3/4"	LA-23	3-13/16"	L-23	3-7/8"	6-11/16"
239		3-3/16"	T-603	3-5/16"	LA-603	3-3/8"	L-603	3-7/16"	6-1/2"
240		4"			LA-41	4-3/16"	L-41	4-1/4"	6-5/8"
262		3.720"			LA-27	3-29/32"	L-27	3-31/32"	7-3/4"
292		3-3/4"			LA-39B	3-15/16"	L-39B	4"	6-1/8"
300		4"			LA-41	4-3/16"	L-41	4-1/4"	6-5/8"
330		3-7/8"			LA-69	4-1/16"	L-69	4-1/8"	6-3/8"
332		3.800"			LA-25	3.987"	L-25	4.050"	6-7/8"
361		4.050"			LA-60	4-15/64"	L-60	4-19/64"	6-3/8"
391		4.050"			LA-60	4-15/64"	L-60	4-19/64"	6-3/8"
401		4-1/8"			LA-67	4-5/16"	L-67	4-3/8"	7-3/4"
460		4.360"			LA-73	4-35/64"	L-73	4-39/64"	6-7/8"
477		4-1/2"			LA-640	4-11/16"	L-640	4-3/4"	8"
534		4-1/2"			LA-640	4-11/16"	L-640	4-3/4"	8"
KOHLER									
K-91		2-3/8"	C-32	2-1/2"	CA-32	2-9/16"	CL-32	2-5/8"	4-1/2"
K-141, 161, 181		2-15/16"	T-215K	3-1/6"	LA-215K	3-1/8"	L-215K	3-3/16"	6-1/2"
KT-17		3-1/8"	T-706A	3-1/4"	LA-706A	3-5/16"	L-706A	3-3/8"	6-7/8"
K-241		3-1/4"	T-34A	3-3/8"	LA-34A	3-7/16"	L-34A	3-1/2"	6-1/2"
K-301, K-532		3-3/8"	T-70D	3-1/2"	LA-70D	3-9/16"	L-70D	3-5/8"	6-1/2"
K-321, K-582		3-1/2"	T-708	3-5/8"	LA-708	3-11/16"	L-708	3-3/4"	6-3/4"
K-341, 361, K-532		3-3/4"	T-44	3-7/8"	LA-44	3-15/16"	L-44	4"	7-1/4"
LEROI									
Compressor		4"			Flanged Replacement Sleeve Part No.: FL-3206				8.765"

CUT TO LENGTH SLEEVES INDUSTRIAL ENGINES



Engine Model	Year	Cyl. Bore	1/16" Wall		3/32" Wall		1/8" Wall		Sleeve Length
				O.D.		O.D.		O.D.	
ONAN									
AH, AK, KH, BH		2-1/2"	C-41B	2-5/8"	CA-41B	2-11/26"	CL-41B	2-3/4"	4-1/2"
1B, AJ		2-3/4"	T-177	2-7/8"	LA-177	2-15/16"	L-177	3"	5-7/8"
ACK, CK, 515D, W2C		3"	T-31	3-1/8"	LA-31	3-3/16"	L-31	3-1/4"	6-3/8"
BJBA, DJ30, DJ120		3-1/4"	T-34A	3-3/8"	LA-34A	3-7/16"	L-34A	3-1/2"	6-1/2"
NH, NHC		3-9/16"	T-21A	3-11/16"	LA-21A	3-3/4"	L-21A	3-13/16"	6"
CW		4"	T-49	4-1/8"	LA-49	4-3/16"	L-49	4-1/4"	6-7/8"
CCK		3.250"	T-34C	3-3/8"	LA-34C	3-7/16"	L-34C	3-1/2"	6"
WAUKESHA									
ICK		2-1/2"	T-208	2-5/8"	LA-208	2-13/16"	L-208	2-3/4"	6-1/2"
FCL		2-3/4"	T-212	2-7/8"	LA-212	2-15/16"	L-212	3"	8-1/4"
FCS		3"	T-30	3-1/8"	LA-30	3-3/16"	L-30	3-1/4"	7-1/2"
FC, FK		3-1/4"	T-605	3-3/8"	LA-605	3-7/16"	L-605	3-1/2"	8-1/8"
WISCONSIN									
AD, H		2-3/4"	T-212	2-7/8"	LA-212	2-15/16"	L-212	3"	8-1/4"
BKD		2-7/8"	T-81	3"	LA-81	3-1/16"	L-81	3-1/8"	4-5/8"
EY-21		2.952"	T-276	3.077"	LA-276	3.140"	L-276	3.202"	6-1/2"
AE, TE, VE		3"	T-31	3-1/8"	LA-31	3-3/16"	L-31	3-1/4"	6-3/8"
		3-1/4"	T-34B	3-3/8"	LA-34B	3-7/16"	L-34B	3-1/2"	5-1/2"
TF, VF		3-1/4"	T-34A	3-3/8"	LA-34A	3-7/16"	L-34A	3-1/2"	6-1/2"
		3-1/2"	T-708A	3-5/8"	LA-708A	3-11/16"	L-708A	3-3/4"	5-1/2"
AG, VG		3-1/2"	T-708	3-5/8"	LA-708	3-11/16"	L-708	3-3/4"	6-3/4"
AH		3-5/8"	T-23	3-3/4"	LA-23	3-13/16"	L-23	3-7/8"	6-11/16"
V465D		3-3/4"	T-75	3-7/8"	LA-75	3-15/16"	L-75	4"	7-1/2"
WISCONSIN ROBIN									
EY-18W, EY-18-3W		2.559"	C-43	2-11/16"	CA-43	2-3/4"	CL-43	2-13/16"	4-1/2"
EY 25W		2.834"	T-56	2.959"	LA-56	3.022"	L-56	3.085"	6-1/4"
EY 27W		2.913"	T-245	3.038"	LA-245	3.100"	L-245	3.163"	6-1/2"
EY 21W		2.952"	T-276	3.077"	LA-276	3.140"	L-276	3.202"	6-1/2"
EY 44W		3.541"	T-273	3.668"	LA-273	3.730"	L-273	3.793"	6-1/2"

Crankshaft Main Bearings Dimension Chart

Size	Description	Part No.	Size	Description	Part No.	Size	Description	Part No.
17 x 47 x 14		6303C3	28 x 72 x 18		B32872	35 x 72 x 17 4mm pinhole		6207YR
20 x 47 x 14		6204C3	30 x 62 x 16 grooved, C4 fit		6206NC4	35 x 72 x 17 4mm pinhole		83B729
20 x 47 x 14 grooved, with ring		6204NR	30 x 62 x 16		6206C3	35 x 72 x 17 pinned		6207JRC4
20 x 52 x 15		6304C3	30 x 62 x 16 grooved		6206N	35 x 72 x 17 pinned, 3mm		83A844A
22 x 50 x 14		6222C4	30 x 62 x 16 grooved with ring		6206NR	35 x 72 x 17 pinned,		
22 x 56 x 16		6322C4	30 x 62 x 16 grvd, w/ring, C4 fit		6206NRC4	3mm grooved w/ring		6207NLT
22 x 56 x 16		6322X	30 x 72 x 18		6306RI	35 x 72 x 27 pinned, 3mm		5207-1LT
25 x 52 x 15		6205C3	30 x 72 x 19		6306C3	35 x 80 x 18		6307X
25 x 52 x 15 grooved		6205N	30 x 72 x 19 grooved		6306N	35 x 80 x 18.5		6307A
25 x 52 x 15 grooved, with ring		6205NR	30 x 72 x 19 grooved, with ring		6306NR	35 x 80 x 21		6307C3
25 x 55 x 15		83A915	30 x 72 x 19 O.D. step		SX06C42	35 x 80 x 21 grooved		6307N
25 x 62 x 16		6305RI	30 x 76 x 17.5		692C3	35 x 80 x 21 grooved,		
25 x 62 x 17		6305C3	32 x 65 x 17		6232C3	5mm pinhole		83B727
25 x 62 x 17 grooved		6305N	32 x 72 x 30 phenalic, 4mm pinhole		83B207	35 x 80 x 21 grooved, with ring		6307NR
25 x 62 x 17 grooved, with ring		6305NR	35 x 72 x 17		6207C3	35 x 80 x 21 pinned		6307JRC4
25 x 62 x 17 grooved, pinned		83406	35 x 72 x 17 C4 fit		6207C4	35 x 80 x 21 pinned, 3mm		83A948
25 x 62 x 17 pinned		83464A	35 x 72 x 17 grooved		6207N	39 x 65 x 18 needle bearings		2MEB671
28 x 58 x 16		6228C3	35 X 72 X 17 grooved, C4 fit		6207NC4	40 x 80 x 18 grooved, with ring		6208NC4
28 x 68 x 18		6328C3	35 x 72 x 17 grooved, with ring		6207NR	40 x 90 x 23		6308C3
28 x 68 x 18 shield		6328LBA	35 x 72 x 17 grvd, w/ring C4 fit		6207NRC4	40 x 90 x 20		6308X

MODEL		Sleeve Inside Diameter	1/16" Wall		3/32" Wall		1/8" Wall		Sleeve Length
			PART NO.	O.D.	PART NO.	O.D.	PART NO.	O.D.	
All Purpose		1-3/8"	T-106	1-1/2"	LA-106	1-9/16"	L-106	1-5/8"	4-1/2"
Copeland, KAG only	**	1-7/16"	C-1	1-9/16"	CA-1	1-5/8"	CL-1	1-11/16"	2"
All Purpose		1-7/16"	T-107	1-9/16"	LA-107	1-5/8"	L-107	1-11/16"	4-1/2"
Copeland, KAE only	**	1-1/2"	C-2	1-5/8"	CA-2	1-11/16"	CL-2	1-3/4"	2"
All Purpose		1-1/2"	T-108	1-5/8"	LA-108	1-11/16"	L-108	1-3/4"	4-1/2"
Copeland, KAJ only	**	1-9/16"	C-4	1-11/16"	CA-4	1-3/4"	CL-4	1-13/16"	2"
All Purpose		1-9/16"	T-109	1-11/16"	LA-109	1-3/4"	L-109	1-13/16"	4-1/2"
All Purpose		1-5/8"	T-110	1-3/4"	LA-110	1-13/16"	L-110	1-7/8"	6-1/4"
Copeland, KAK-KAA	**	1-11/16"	C-5	1-13/16"	CA-5	1-7/8"	CL-5	1-15/16"	2"
All Purpose		1-11/16"	T-111	1-13/16"	LA-111	1-7/8"	L-111	1-15/16"	6-1/4"
Copeland, EAA-EAC-ERC-ERA	**	1-3/4"	C-6	1-7/8"	CA-6	1-15/16"	CL-6	2"	2-9/16"
All Purpose		1-3/4"	T-112	1-7/8"	LA-112	1-15/16"	L-112	2"	6-1/2"
Carrier, 6D40	**	1-13/16"	C-7	1-15/16"	CA-7	2"	CL-7	2-1/16"	3-1/4"
	**	1-13/16"	C-8	1-15/16"	CA-8	2"	CL-8	2-1/16"	4-1/2"
All Purpose		1-13/16"	T-113	1-15/16"	LA-113	2"	L-113	2-1/16"	6-1/2"
Copeland, KAL-KAT	**	1-7/8"	C-9	2"	CA-9	2-1/16"	CL-9	2-1/8"	1-15/16"
Copeland, EAB-EAD,ERB-ERF	**	1-7/8"	C-10	2"	CA-10	2-1/16"	CL-10	2-1/8"	2-9/16"
		1-7/8"	T-114D	2"	LA-114D	2-1/16"	L-114D	2-1/8"	8-3/4"
All Purpose		1-7/8"	T-114	2"	LA-114	2-1/16"	L-114	2-1/8"	6-1/2"
Copeland, EAL-EAU-EAJ-ERPJ-3AB	**	1-15/16"	C-11	2-1/16"	CA-11	2-1/8"	CL-11	2-3/16"	2-9/16"
4R & 6R Bearing	**	1-15/16"	C-12	2-1/16"	CA-12	2-1/8"	CL-12	2-3/16"	4-7/8"
	**	1-15/16"	C-13	2-1/16"	CA-13	2-1/8"	CL-13	2-3/16"	5"
All Purpose		1-15/16"	T-115	2-1/16"	LA-115	2-1/8"	L-115	2-3/16"	6-1/2"
Copeland, EAL	**	2"	C-50	2-1/8"	CA-50	2-3/16"			2-5/8"
Carrier-06DA	**	2"	C-14	2-1/8"	CA-14	2-3/16"	CL-14	2-1/4"	3-1/4"
All Purpose		2"	T-200	2-1/8"	LA-200	2-3/16"	L-200	2-1/4"	6-1/2"
All Purpose		2-1/16"	T-201	2-3/16"	LA-201	2-1/4"	L-201	2-3/16"	6-1/2"
Copeland, 3AJ	*	2-1/8"	C-15	2-1/4"	CA-15	2-5/16"	CL-15	2-3/8"	2-9/16"
	**	2-1/8"	C-17	2-1/4"	CA-17	2-5/16"	CL-17	2-3/8"	3-3/4"
All Purpose	*	2-1/8"	T-202	2-1/4"	LA-202	2-5/16"	L-202	2-3/8"	6-1/2"
Copeland	*	2-3/16"	C-18	2-5/16"	CA-18	2-3/8"	CL-18	2-7/16"	2-9/16"
	*	2-3/16"	C-19	2-5/16"	CA-19	2-3/8"	CL-19	2-7/16"	3"
	*	2-3/16"	C-20	2-5/16"	CA-20	2-3/8"	CL-20	2-7/16"	3-1/16"
	*	2-3/16"	C-21	2-5/16"	CA-21	2-3/8"	CL-21	2-7/16"	3-9/16"
Copeland, NRM-NRN	*	2-3/16"	C-22	2-5/16"	CA-22	2-3/8"	CL-22	2-7/16"	3-11/16"
Copeland, 9RA-9RK-9TK-9WA-9WJ	*	2-3/16"	C-23	2-5/16"	CA-23	2-3/8"	CL-23	2-7/16"	4-7/16"
All Purpose	**	2-3/16"	T-203	2-5/16"	LA-203	2-3/8"	L-203	2-7/16"	6-1/2"
Copeland, 3AH	*	2-1/4"	C-24	2-3/8"	CA-24	2-7/16"	CL-24	2-1/2"	2-9/16"
Copeland, LAH-LWH-NRH		2-1/4"	C-25	2-3/8"	CA-25	2-7/16"	CL-25	2-1/2"	3-11/16"
All Purpose	**	2-1/4"	T-204	2-3/8"	LA-204	2-7/16"	L-204	2-1/2"	6-1/2"
Copeland, 3RK	*	2-5/16"	C-26	2-7/16"	CA-26	2-1/2"	CL-26	2-9/16"	2-9/16"
		2-5/16"	C-27	2-7/16"	CA-27	2-1/2"	CL-27	2-9/16"	4-7/8"

COMPRESSOR SLEEVES



MODEL	ve de eter	1/16" Wall		3/32" Wall		1/8" Wall		Sleeve Length	
		PART NO.	O.D.	PART NO.	O.D.	PART NO.	O.D.		
All Purpose		2-5/16"	T-205	2-7/16"	LA-205	2-1/2"	L-205	2-9/16"	6-1/2"
Curtis Compressor		2-5/16"	T-205D	2-7/16"	LA-205D	2-1/2"	L-205D	2-9/16"	7-1/2"
Copeland, LAL-LWL	*	2-3/8"	C-28	2-1/2"	CA-28	2-9/16"	CL-28	2-5/8"	3-11/16"
	*	2-3/8"	C-30	2-1/2"	CA-30	2-9/16"	CL-30	2-5/8"	3-3/4"
Copeland, 9RB-9RC-9TL-9WC-9RP	*	2-3/8"	C-31	2-1/2"	CA-31	2-9/16"	CL-31	2-5/8"	4-7/16"
9R9	*	2-3/8"	C-32	2-1/2"	CA-32	2-9/16"	CL-32	2-5/8"	4-1/2"
All Purpose		2-3/8"	T-206	2-1/2"	LA-206	2-9/16"	L-206	2-5/8"	6-1/2"
Copeland, LAC-LWC-LAM-LWM-NRL-NRA-NRD	*	2-7/16"	C-34	2-9/16"	CA-34	2-5/8"	CL-34	2-11/16"	3-11/16"
LSG	*	2-7/16"	C-35	2-9/16"	CA-35	2-5/8"	CL-35	2-11/16"	3-3/4"
Copeland, MRG	*	2-7/16"	C-36	2-9/16"	CA-36	2-5/8"	CL-36	2-11/16"	4-1/16"
Copeland, 9RSI-9RT-9RS3-9TH	*	2-7/16"	C-37	2-9/16"	CA-37	2-5/8"	CL-37	2-11/16"	4-7/16"
All Purpose		2-7/16"	T-207	2-9/16"	LA-207	2-5/8"	L-207	2-11/16"	6-1/2"
Copeland, 4RA-4RE-6RA-6RB-6RN-6RE	*	2-1/2"	C-38	2-5/8"	CA-38	2-11/16"	CL-38	2-3/4"	3-1/8"
	*	2-1/2"	C-39	2-5/8"	CA-39	2-11/16"	CL-39	2-3/4"	3-1/4"
Copeland, MRA-MRF-MWF	*	2-1/2"	C-40	2-5/8"	CA-40	2-11/16"	CL-40	2-3/4"	4-1/16"
	*	2-1/2"	C-41	2-5/8"	CA-41	2-11/16"	CL-41	2-3/4"	4-1/8"
	*	2-1/2"	T-208D	2-5/8"	LA-208D	2-11/16"	L-208D	2-3/4"	7-1/4"
	*	2-1/2"	T-208E	2-5/8"	LA-208E	2-11/16"	L-208E	2-3/4"	8-5/8"
All Purpose		2-1/2"	T-208	2-5/8"	LA-208	2-11/16"	L-208	2-3/4"	6-1/2"
Copeland, MRH	*	2-9/16"	C-42	2-11/16"	CA-42	2-3/4"	CL-42	2-13/16"	4-1/16"
	*	2-9/16"	C-43	2-11/16"	CA-43	2-3/4"	CL-43	2-13/16"	4-1/2"
All Purpose	*	2-9/16"	T-209	2-11/16"	LA-209	2-3/4"	L-209	2-13/16"	6-1/2"
	*	2-5/8"	C-44	2-3/4"	CA-44	2-13/16"	CL-44	2-7/8"	3-7/16"
Copeland, MRB-MRC	*	2-5/8"	C-45	2-3/4"	CA-45	2-13/16"	CL-45	2-7/8"	4-1/16"
All Purpose	*	2-5/8"	T-210	2-3/4"	LA-210	2-13/16"	L-210	2-7/8"	6-1/2"
	*	2-11/16"	C-46	2-13/16"	CA-46	2-7/8"	CL-46	2-15/16"	3-1/8"
Copeland, 4RH-4RK-4RL-6RH-6RK-6RL-6RP-6TH	*	2-11/16"	C-47	2-13/16"	CA-47	2-7/8"	CL-47	2-15/16"	3-7/16"
Carrier-06EA	*	2-11/16"	C-48	2-13/16"	CA-48	2-7/8"	CL-48	2-15/16"	4-3/16"
Trane, All Purpose		2-11/16"	T-211	2-13/16"	LA-211	2-7/8"	L-211	2-15/16"	8-1/4"
All Purpose		2-3/4"	T-212	2-7/8"	LA-212	2-15/16"	L-212	3"	8-1/4"
All Purpose		2-13/16"	T-213	2-15/16"	LA-213	3"	L-213	3-1/16"	8-1/4"
All Purpose		2-7/8"	T-214	3"	LA-214	3-1/16"	L-214	3-1/8"	8-1/4"
Copeland, 4RJ-6RJ	*	2-15/16"	C-49	3-1/16"	CA-49	3-1/8"	CL-49	3-3/16"	3-5/16"
All Purpose		2-15/16"	T-215	3-1/16"	LA-215	3-1/8"	L-215	3-3/16"	8-1/4"
		3"			LA-300D	3-3/16"	L-300D	3-1/4"	11-1/8"
All Purpose		3"	T-300	3-1/8"	LA-300	3-3/16"	L-300	3-1/4"	8-1/4"
Quincy 15 H.P.		4"			LA-400L	4-3/16"	L-400L	4-1/4"	10-3/4"

L.A. SLEEVE

Ductile - Iron Sleeves

These custom sleeves are manufactured using High-tensile strength, High hardness centrifugal cast ductile iron. Usage of this material is recommended for extreme conditions; such as fuel blown, alcohol fueled aluminum block motors. **Los Angeles Sleeve Co.** manufactures nodular sleeves for many popular aluminum block motors.

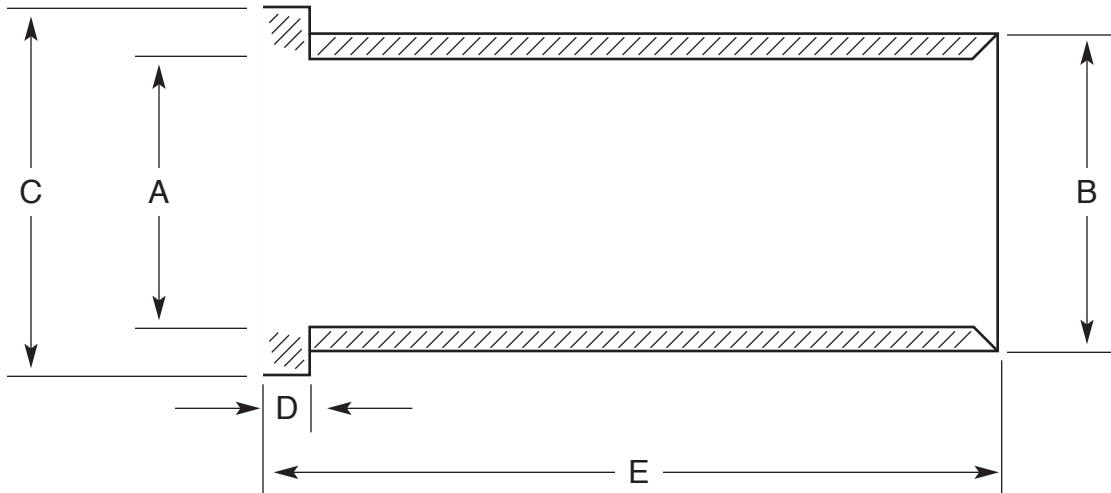

CHEVROLET						
APPLICATION	PART NO.	A	B	C	D	E
350	FL-3133D	3.970"	4.200"	4.390"	.125"	6"
350	FL-3135D	3.970"	4.254"	4.500"	.200"	6"
400	FL-3137D	4.090"	4.315"	4.440"	.125"	6-3/4"
400	FL-3138D	4.090"	4.375"	4.500"	.125"	6-3/4"
427, 454	FL-3139D	4.210"	4.500"	4.625"	.200"	6-3/4"
Bow-Tie Block	L-64	4.470"	4.754"	No Flange		7-3/4"

FORD						
APPLICATION	PART NO.	A	B	C	D	E
429 Short Block	FL-3141	4.245"	4.701"	5.200"	.324"	6.250"
429 Short Block	FL-3142	4.495"	4.801"	5.200"	.324"	6.250"
429 Tall Block	FL-3143	4.370"	4.801"	5.200"	.324"	7.150"
429 Tall Block	FL-3144	4.495"	4.801"	5.200"	.324"	7.150"
8.3L Tall Block	FL-3145	4.495"	4.820"	5.200"	.324"	7.150"
8.3L Short Block	FL-3146	4.245"	4.625"	5.200"	.324"	6.350"
8.3L Tall Block	FL-3147	4.245"	4.625"	5.200"	.324"	6.875"
8.3L Tall Block	FL-3148	4.432"	4.625"	5.200"	.324"	6.875"
8.3L Tall Block	FL-3149	4.432"	4.687"	5.200"	.324"	6.875"
8.3L Tall Block	FL-3150	4.432"	4.700"	5.200"	.324"	6.875"

RODECK						
APPLICATION	PART NO.	A	B	C	D	E
Aluminum Race Block	FL-3177	4.125"	4.301"	4.475"	.189"	5.575"
	FL-3164	4.449"	4.636"	4.995"	.252"	6.350"

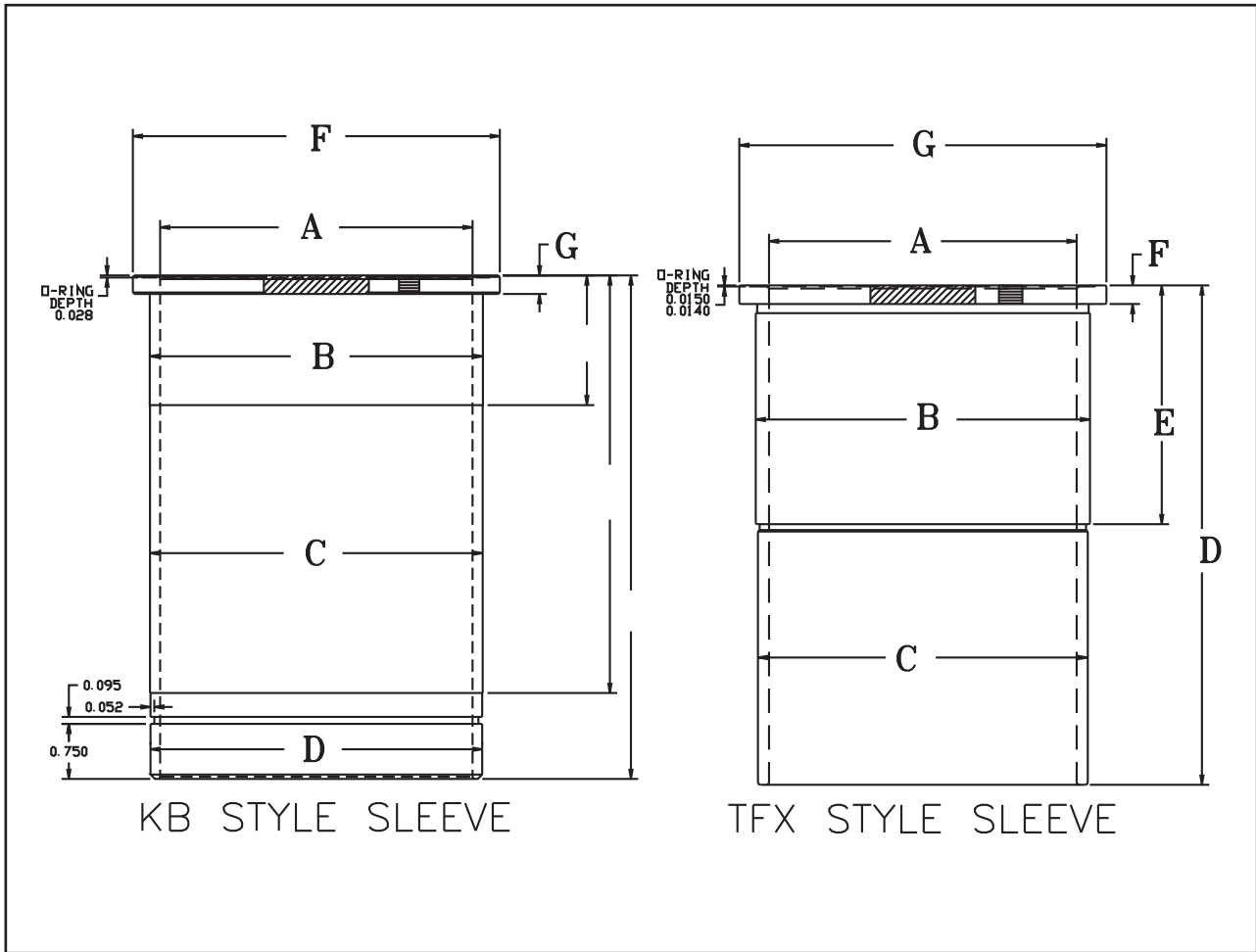

TOP FUEL						
PART #	A	B	C	D	OAL	# OF SKIRT O-RINGS
KB1	4.252"	4.6345"	4.625"	4.6145"	6.86"	1
KB2	4.187"	4.6345"	4.625"	4.6145"	6.86"	1
KB3	4.187"	4.5345"	4.525"	4.5145"	6.96"	1
KB4	4.187"	4.6345"	4.525"	4.5145"	6.96"	1
KB5	4.187"	4.5345"	4.525"	4.5145"	6.86"	1
KB8	4.187"	4.6345"	4.625"	4.6145"	6.96"	1
TFX1	4.187"	4.55"	4.49"	0	6.800"	0
TFX4	4.252"	4.61"	4.55"	0	6.800"	0
TFX9	4.187"	4.610"	4.550"	0	6.800"	0
TFX10	4.1875"	4.449"	4.409"	0	6.800"	0
TFX11	4.375"	4.610"	4.550"	0	6.300"	0

FRACTION / DECIMAL EQUIVALENT CHART

1/64"	.015625"	33/64"	.515625"
1/32"	.03125"	17/32"	.53125"
3/64"	.046875"	35/64"	.546875"
1/16"	.0625"	9/16"	.5625"
5/64"	.078125"	37/64"	.587125"
3/32"	.09375"	19/32"	.59375"
7/64"	.109375"	39/64"	.609375"
1/8"	.125"	5/8"	.625"
9/64"	.140625"	41/64"	.640625"
5/32"	.15625"	21/32"	.65625"
11/64"	.171875"	43/64"	.671875"
3/16"	.1875"	11/16"	.6875"
13/64"	.203125"	45/64"	.703125"
7/32"	.21875"	23/32"	.71875"
15/64"	.234375"	47/64"	.734375"
1/4"	.250"	3/4"	.750"
17/64"	.265625"	49/64"	.765625"
9/32"	.28125"	25/32"	.78125"
19/64"	.296875"	51/64"	.796875"
5/16"	.3125"	13/16"	.8125"
21/64"	.328125"	53/64"	.828125"
11/32"	.34375"	27/32"	.84375"
23/64"	.359375"	55/64"	.859375"
3/8"	.375"	7/8"	.875"
25/64"	.390625"	57/64"	.890625"
13/32"	.40625"	29/32"	.90625"
27/64"	.421875"	59/64"	.921875"
7/16"	.4375"	15/16"	.9375"
29/64"	.453125"	61/64"	.953125"
15/32"	.46875"	31/32"	.96875"
31/64"	.484375"	63/64"	.984375"
1/2"	.500"	1"	1.00"

METRIC CONVERSION - 1MM = .03937"

MILLIMETER / DECIMAL EQUIVALENT CHART

MM	DECIMAL	MM	DECIMAL	MM	DECIMAL	MM	DECIMAL
1	0.03937"	39	1.53562"	77	3.03187"	115	4.52811"
2	0.07875"	40	1.57500"	78	3.07124"	116	4.56749"
3	0.11812"	41	1.61437"	79	3.11062"	117	4.60686"
4	0.15750"	42	1.65375"	80	3.14999"	118	4.64624"
5	0.19687"	43	1.69312"	81	3.18937"	119	4.68561"
6	0.23625"	44	1.73250"	82	3.22874"	120	4.72499"
7	0.27562"	45	1.77187"	83	3.26812"	121	4.76436"
8	0.31500"	46	1.81125"	84	3.30749"	122	4.80374"
9	0.35437"	47	1.85062"	85	3.34687"	123	4.84311"
10	0.39375"	48	1.89000"	86	3.38624"	124	4.88249"
11	0.43312"	49	1.92937"	87	3.42562"	125	4.92186"
12	0.47250"	50	1.96875"	88	3.46499"	126	4.96124"
13	0.51187"	51	2.00812"	89	3.50437"	127	5.00061"
14	0.55125"	52	2.04749"	90	3.54374"	128	5.03999"
15	0.59062"	53	2.08687"	91	3.58312"	129	5.07936"
16	0.63000"	54	2.12624"	92	3.62249"	130	5.11874"
17	0.66937"	55	2.16562"	93	3.66187"	131	5.15811"
18	0.70875"	56	2.20499"	94	3.70124"	132	5.19749"
19	0.74812"	57	2.24437"	95	3.74062"	133	5.23686"
20	0.78750"	58	2.28374"	96	3.77999"	134	5.27624"
21	0.82687"	59	2.32312"	97	3.81937"	135	5.31561"
22	0.86625"	60	2.36249"	98	3.85874"	136	5.35499"
23	0.90562"	61	2.40187"	99	3.89812"	137	5.39436"
24	0.94500"	62	2.44124"	100	3.93749"	138	5.43374"
25	0.98437"	63	2.48062"	101	3.97686"	139	5.47311"
26	1.02375"	64	2.51999"	102	4.01624"	140	5.51249"
27	1.06312"	65	2.55937"	103	4.05561"	141	5.55186"
28	1.10250"	66	2.59874"	104	4.09499"	142	5.59124"
29	1.14187"	67	2.63812"	105	4.13436"	143	5.63061"
30	1.18125"	68	2.67749"	106	4.17374"	144	5.66999"
31	1.22062"	69	2.71687"	107	4.21311"	145	5.70936"
32	1.26000"	70	2.75624"	108	4.25249"	146	5.74874"
33	1.29937"	71	2.79562"	109	4.29186"	147	5.78811"
34	1.33875"	72	2.83499"	110	4.33124"	148	5.82749"
35	1.37812"	73	2.87437"	111	4.37061"	149	5.86686"
36	1.41750"	74	2.91374"	112	4.40999"	150	5.90623"
37	1.45687"	75	2.95312"	113	4.44936"		
38	1.49625"	76	2.99249"	114	4.48874"		

CUSTOM SLEEVES

L.A. SLEEVE CO. produces centrifugally spun-cast chrome-moly iron alloy cylinder sleeves for all engine repair markets, which include Automotive, Drag Race, Nascar, Indy Car, Circle Track, Heavy Duty, Industrial, Tractor, Motorcycle, ATV, PWC, Snowmobile and Marine Industries.

Since the acquisition of our first CNC lathe in 1980, our manufacturing facility has grown to over 30,000 square feet and is filled with more than 30 CNC lathes and mills. We produce high quality cylinder sleeves accurately and efficiently.

Centerless grinding of outside diameters of LASCO sleeves provides for exact roundness and exact size, which is controlled by rigid inspection of one-half thousandth of an inch. We invite comparison of our sleeves with other leading makes for size, roundness and finish.

Custom-made cylinder sleeves to your specifications are available from L.A.SLEEVE. Quantities from one sleeve to full production are gladly accepted.

In many instances, catalog item sleeves that are on the shelf may be close in size to fulfill the requirements. Call our technical staff, we will be glad to assist you!

The two most important elements of custom sleeve design are the size required and the material requirements. L.A.SLEEVE stocks an array of raw material sizes ranging from 1-3/4" (45mm) to 8" (200mm).

Cylinder sleeves may be manufactured in different wall thicknesses within this range.

There are three different materials that L.A.SLEEVE uses for custom sleeves. The first and most popular is the Moly 2000 chrome-moly iron. This material covers all applications from hi-performance to small engine. Moly 2000 iron is available in all sizes and the material chosen for ninety percent of all sleeves made. Unless otherwise specified, we make custom sleeves from this material.

The second material is ductile iron (also known as Nodular). This is a high tensile strength, air-quenched iron material and is used for specific high-performance applications such as fuel blown motors. Sleeve availability is limited to a small range of casting sizes.

The third available is aluminum, A355 centrifugally spun or A6061-T651 aluminum. Sleeve sizes are very limited. Also, aluminum sleeves are only made for applications where plating is required.

When designing a sleeve, you need to determine the wall thickness required. You may also design the sleeve using the inside diameter and outside diameter to produce the desired wall thickness.

The method to determine wall thickness: O.D. minus I.D. divided by 2 = wall thickness.

Next, determine the proper length. Finally, if a flange is required, determine the flange outside diameter and flange length (also known as flange thickness).

Allow the inside diameter to be .030" underside the actual finish bore size dimension. This will give the machine shop bore stock after the sleeve is installed into the cylinder or block. Always note the actual finish bore size as a reference on the drawing or dimension spec sheet.

Some sleeve applications require the bore size to be finish honed to the exact size. L.A.SLEEVE is able to provide the sleeve bore with a sized finish hone. Please be specific when requesting this application.

Some custom sleeves may require O-Ring grooves, flange clearances, notches or radius cuts. L.A.SLEEVE will machine any of these requirements into the custom sleeve. Provide a detailed drawing of all required custom machining and dimensions for a quotation.

Choose one of the drawing templates (Page 2) that most closely matches your requirement. Fill in the requested dimensions and FAX or email the drawing to L.A.SLEEVE for a quotation and delivery.

If you do not see a drawing that matches your requirement, simply provide your own drawing and we will quote the sleeve per your requirements. Or call direct for technical assistance in designing your custom sleeve. Our staff will be glad to help!



Serving The
Motorsports
Industry For
Over 66 Years



Phone: 562 945.7578
Email: info@lasleeve.com
Web: www.lasleeve.com

Toll Free: 800 822.6005

12051 Rivera Road, Santa Fe Springs, CA 90670

